

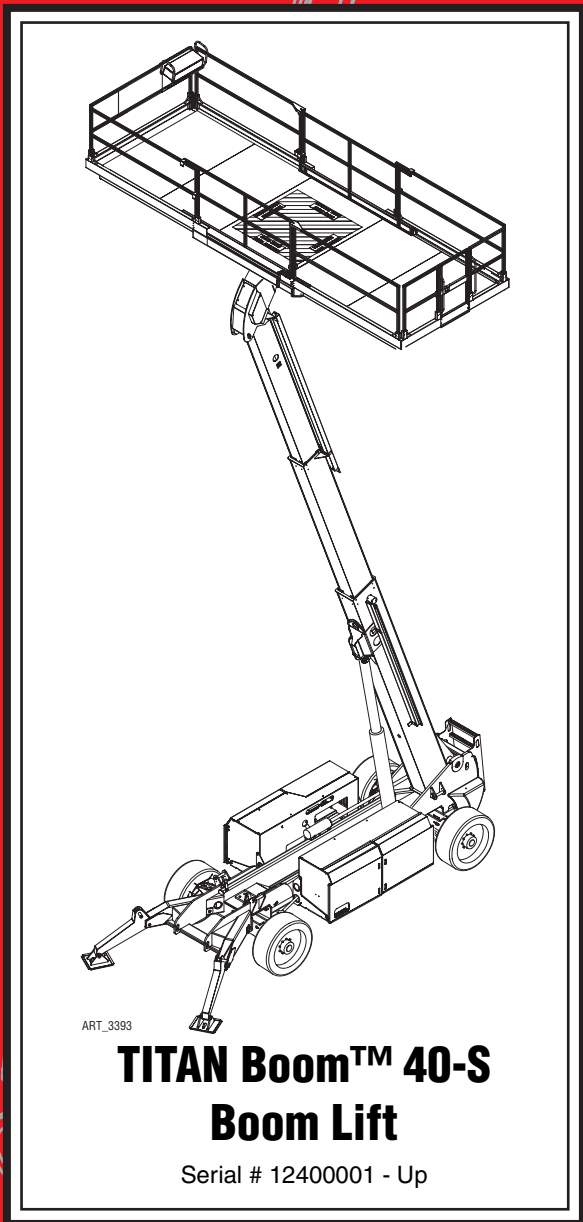

Operator's Manual

CE/Australian Specifications

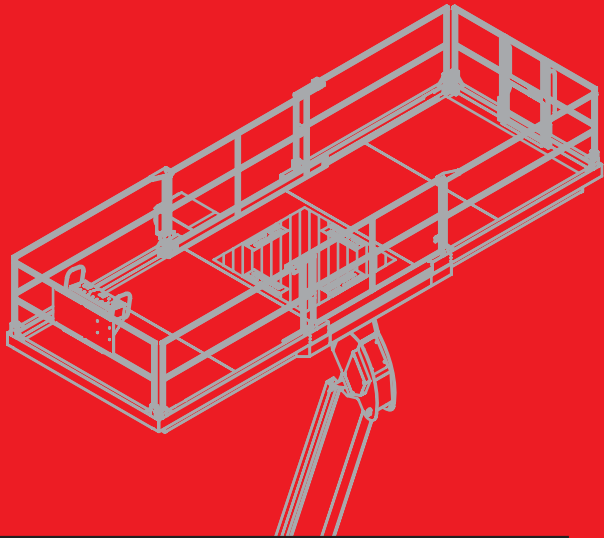

Specifications	inside cover
Introduction	1
Safety	2
Safety Alert Symbols	3
Electrocution Hazard	4
Tip-over Hazards	6
Fall Hazards	7
Collision Hazards	7
Additional Safety Hazards	8
Battery Safety	8
Controls & Components	9
Component Locations	9
Platform Controls	10
Base Controls	12
Workplace Inspection	14
Operating Instructions & Function Tests	15
Prestart	15
Starting Engine from Base Controls	16
Starting Engine from Platform Controls	17
Base Controls Operation and Test	18
Platform Control Operation and Test	23
Shutdown Procedure	30
Emergency Lowering System	31
Fold Down Platform Railings	32
Platform Capacity & Material Loading	34
Machine Inspections and Maintenance	35
Using The Maintenance Chock	36
Pre-Start Inspection Checklist	37
Frequent Inspection Checklist	38
Annual Inspection Report	39
Maintenance	40
Routine Maintenance	40
Frequent and Annual Maintenance	40
Lubrication	41
Warning and Instructional Decals	42
Troubleshooting	45
Transport and Lifting Instructions	46
Loading	46
Driving or Winching onto or off of a Transport Vehicle	46
Securing to Truck or Trailer for Transport	47
Lifting Instructions	48

92296
July 2012

—Specifications—

TITAN Boom™ 40-S			
Working Height*	46 ft	14.2 m	
Platform Height	40 ft	12.2 m	
Maximum Drive Height	30 ft	9.1 m	
Maximum Forward Reach w/ Stabilizers	26 ft 6 in	8 m	
Machine Weight** (Unloaded)	24250 lb	11000 kg	
Lift Capacity	Total	4000 lb	1810 kg
	Load Zone	3000 lb	1360 kg
	Personnel & Tools Evenly Distributed	1000 lb	450 kg
Maximum Occupants	4		
Stowed Height	Rails Up	118 in	3 m
	Rails Folded Down	84 in	2.13 m
Overall Length	22 ft 6 in	6.9 m	
Overall Width	96 in	2.44 m	
Wheel Base	152 in	3.85 m	
Wheel Track	82 in	2.08 m	
Platform Dimensions	Length	22 ft	6.7 m
	Platform Width	90 in	2.28 m
	Loading Height	72 in	1.83 m
Turning Radius, (4 Wheel Steer)	Inside	8 ft	2.4 m
	Outside	19 ft	5.8 m
Ground Clearance	18 in	46 cm	
Lift/Lower Speeds	50 sec/ 50 sec		
Extend/Retract Speeds	30 sec/ 30 sec		
Platform Translation Speed	15 sec		
Drive Speed (Proportional)	Stowed	0-4 mph	0-6.4 km/h
	Raised or extended	0-.5 mph	0-.8 km/h
Gradeability	Stowed, downhill	40%/22°	
	Stowed, uphill	40%/22°	
Approach Angle	38%/21°		
Breakover Angle	40%/22°		Engine Kubota V2403-T
Platform Rotation	180° (+90°, -90°)		Fuel Type Diesel
Frame Level	10° each side		Fuel Capacity 32 gal 120 liter
Maximum Operating Wind Speed	28 mph	12.5 m/sec (45 km/h)	Alternator 40 amp
Ground Pressure/Wheel (Maximum)	160 psi	11.2 kg/cm ²	Battery Two 1000 CCA 12V
Maximum Wheel Load	9600 lbs	4350 kg	Noise Level 86 dB(A) @ 1m
Tire Size	37 in. od	.94 m od	Control System 12V DC
Wheel Lug Nut Torque	150 ft/lb	203 Nm	Brakes 4 wheel multi disc
Hydraulic Pressure	Drive System	4350 psi	300 bar
	Main System	3000 psi	207 bar
			Maximum Vibration does not exceed 2.5 m/sec ² at operator's position
Hydraulic Fluid Capacity	40 gal	150 liter	Ambient Operating Range -30° C minimum; 50° C maximum
Meets applicable requirements of CE EN280:2001 + A2:2009 and Australian Standard AS1418.10(Int)--2004 Part 10: Elevated Work Platforms. *Working Height adds 6 feet (2 m) to platform height. **Weight may increase with certain options or country standards.			

Introduction

This Operator's Manual has been designed to provide you, the owner, user or operator, with the instructions and operating procedures essential to properly and safely operate your MEC Aerial Work Platform for positioning personnel, along with their necessary tools and materials, to overhead work locations.



The Operator's Manual must be read and understood prior to operating your MEC Aerial Work Platform. The user/operator should not accept operating responsibility until he/she has read and understands the operator's manual as well as having operated the MEC Aerial Work Platform under supervision of an authorized, trained and qualified operator.

It is essential that the operator of the aerial work platform is not alone on the workplace during operation.

Modifications of this machine from the original design and specifications without written permission from MEC are strictly forbidden. A modification may compromise the safety of the machine, subjecting operator(s) to serious injury or death.

Your MEC Aerial Work Platform has been designed, built, and tested to provide safe, dependable service. Only authorized, trained and qualified personnel shall be allowed to operate or service the machine.

MEC, as manufacturer, has no direct control over machine application and operation. Proper safety practices are the responsibility of the owner, user and operator.

If there is a question on application and/or operation contact:



MEC Aerial Platform Sales Corp.

1401 South Madera Ave • Kerman, CA 93630 USA

Ph: 1-877-635-5438 • 559-842-1500 • Fax: 559-842-1522

www.mecawp.com

Safety

DO NOT operate this machine until you have read and understood this manual, have performed the Workplace Inspection, Pre-Start Inspection and Routine Maintenance, and have completed all the test operations detailed in the Operating Instructions section.

Failure to read, understand and follow all safety rules, warnings, and instructions could result in serious injury or death. For your safety and the safety of those around you, you must operate your machine as instructed in this manual.

MEC designs aerial work platforms to safely and reliably position personnel, along with their necessary tools and materials, at overhead work locations. The owner/user/operator of the machine should not accept responsibility for the operation of the machine unless properly trained.



NEVER perform work or inspection on the machine with the platform elevated without first blocking the boom assembly with the Maintenance Chock.

Safety Alert Symbols

MEC manuals and decals use symbols and colors to help you recognize important safety, operation and maintenance information.



RED – Indicates an imminently hazardous situation which, if not avoided, will result in death or serious injury.



ORANGE – Indicates a potentially hazardous situation which, if not avoided, could result in death or serious injury.



YELLOW with alert symbol – Indicates a potentially hazardous situation which, if not avoided, may result in minor or moderate injury.



YELLOW without alert symbol – Indicates a potentially hazardous situation which, if not avoided, may result in property damage.



GREEN – Indicates operation or maintenance information.

Fall Protection

Maximum 4 Occurrences

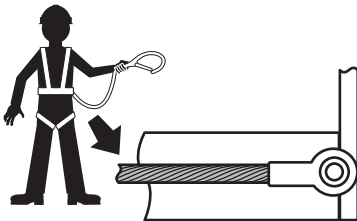

Personal fall protection equipment (PFPE) is required when operating this machine.

All PFPE must comply with employer and job site rules and applicable governmental regulations, and must be inspected and used in accordance with the PFPE manufacturer's instructions.

ALWAYS wear approved fall protection, properly attached to an anchor cable, when operating the machine.

Electrocution Hazard



ELECTROCUTION HAZARD!!! THIS MACHINE IS NOT INSULATED!

DEATH OR SERIOUS INJURY will result from contact with or inadequate clearance from any electrically charged conductor.

You must maintain a CLEARANCE OF AT LEAST 10 FEET (3.05 m) between any part of the machine, or its load, and any electrical line or apparatus carrying over 300 Volts up to 50,000 Volts. One foot (30.5 cm) additional clearance is required for every additional 30,000 Volts.

Observe Minimum Safe Approach Distance.

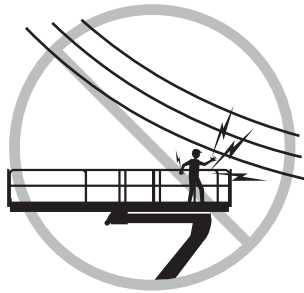

DO NOT work in close proximity to, or in contact with, energized power lines and electrical equipment. This machine is not insulated and WILL NOT protect the operator from injury or the machine from damage.

Refer to the following diagram and all applicable governmental regulations for the minimum safe distances from energized power lines and electrical equipment.

DO NOT touch the machine if it contacts energized power lines.

Personnel in the platform:

- Move away from the platform rails,
- DO NOT attempt to operate the machine, and
- DO NOT touch any part of the machine until energized power lines are shut off.

Personnel on the ground:

- DO NOT approach the machine and
- DO NOT touch or attempt to operate the machine until energized power lines are turned off.

Do not operate the machine during electrical storms or lightning.

DO NOT use the machine as a ground for welding unless properly equipped with a weld line to platform option.

Minimum Safe Approach Distance

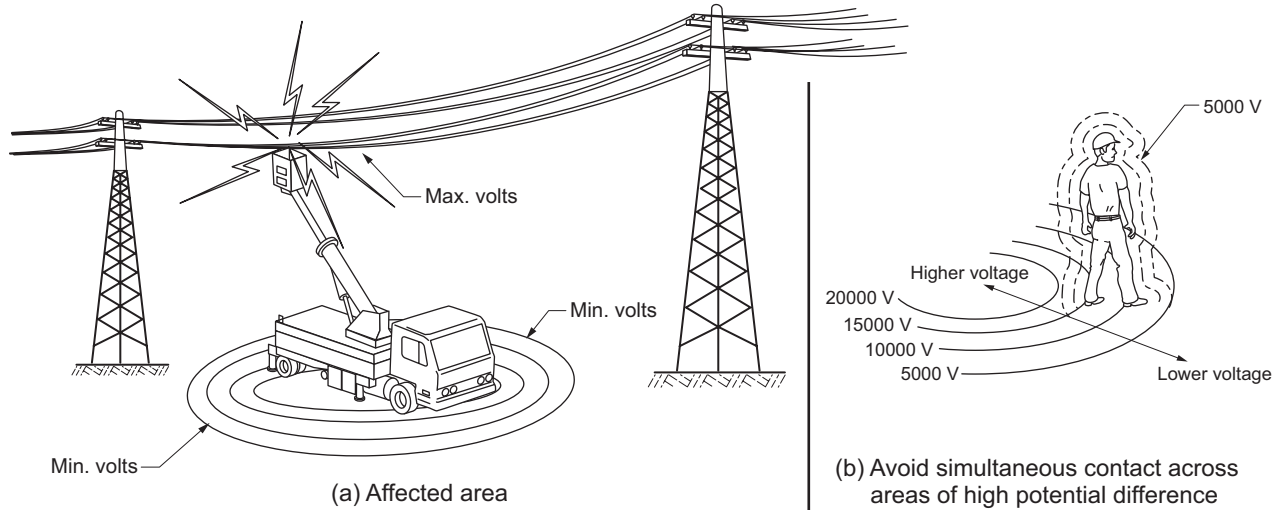

CLEARANCES FROM LIVE AERIAL CONDUCTORS

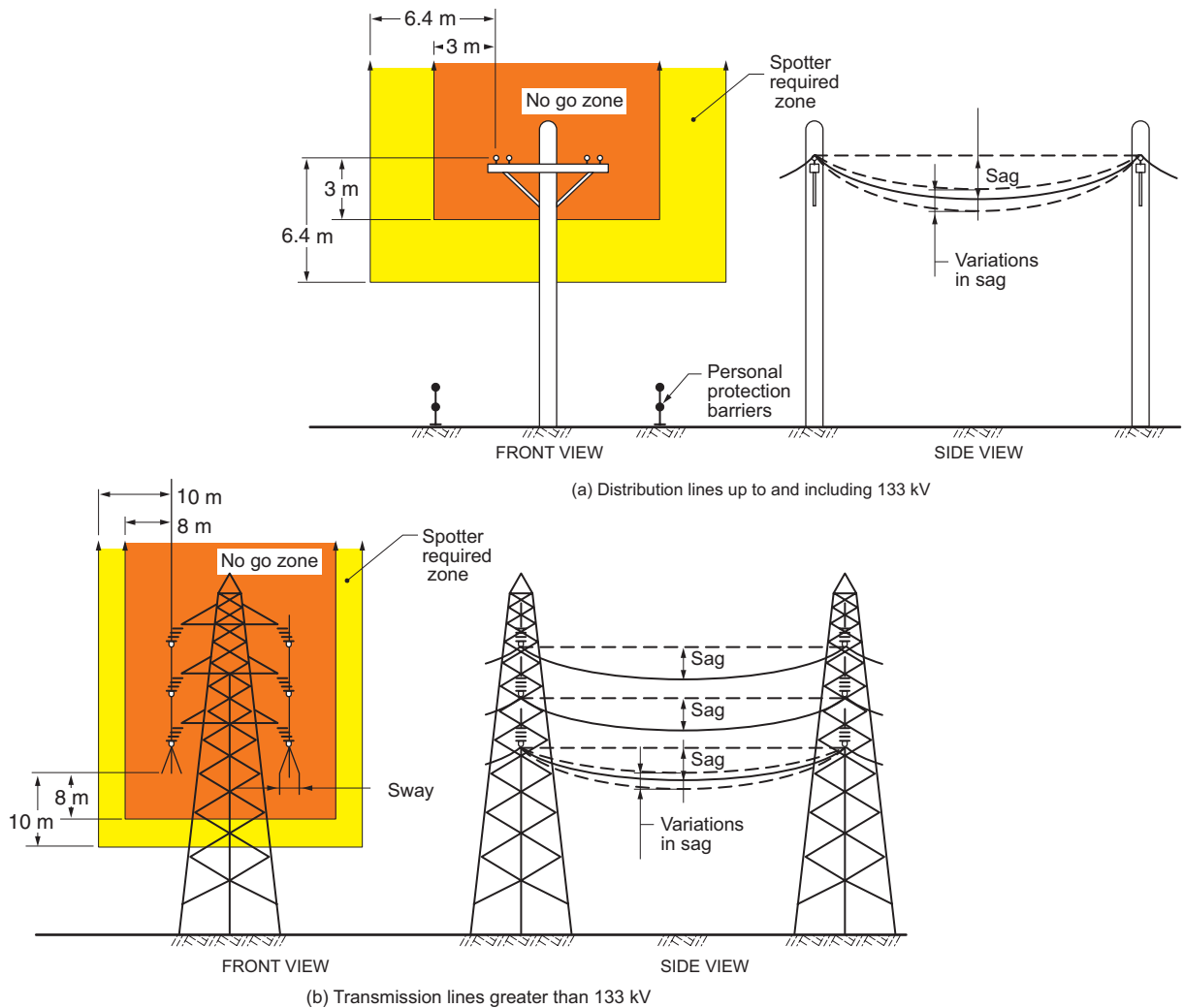

LEGEND

- = No shading, in the front views, indicates no proximity requirements
- = Light shading indicates spotter is required
- = Heavy shading indicates the NO GO ZONE

ART_3265

Tip-over Hazards



DO NOT OVERLOAD

DO NOT exceed the maximum platform capacity (See *Platform Capacity & Material Loading* on page 34). The weight of options and accessories will reduce the rated platform capacity and must be factored into the total platform load. Refer to the decals on the options.

DO NOT elevate the platform when the machine is on a surface that is soft and / or on a slope.

STOP if the alarm sounds and the red light illuminates when the platform is raised. Use extreme caution to lower the platform.

Driving: DO NOT drive the machine on a slope that exceeds the maximum uphill or downhill slope rating. Slope rating applies to machines in the stowed position.

Driving in stowed position: use extreme care and reduce speed when driving across uneven terrain, debris, unstable or slippery surfaces, and near holes or drop-offs.

Driving with the platform elevated: DO NOT drive on or near uneven terrain, unstable surfaces, curbs, drop-offs or other hazardous conditions.

DO NOT push off or pull toward any object outside the platform.

Maximum Allowable Side Force

CE
400 N



DO NOT DRIVE ON IRREGULAR OR UNSTABLE SURFACE

DO NOT elevate the platform when wind speeds are in excess of 28 m.p.h. (12.5 m/s). If wind speeds exceed 28 m.p.h. (12.5 m/s) when the platform is elevated, carefully lower the platform and discontinue operation.

DO NOT increase the surface area of the platform (i.e. cover the rails with tarp or plywood). Increased surface area exposed to the wind will decrease machine stability.

DO NOT attach overhanging loads or use the machine as a crane.

NEVER transport tools and materials unless they are firmly secured. Secure all tools and loose materials.

NEVER alter or disable any machine components.

NEVER replace any part of the machine with items of different weight or specification.

NEVER modify or alter the work platform without written permission from MEC.

NEVER place ladders or scaffolds in the platform or against any part of the machine.

NEVER use the machine on a moving or mobile surface or vehicle.

Ensure that all tires are in good condition and lug nuts are properly torqued.



DO NOT PUSH OR PULL OBJECTS OUTSIDE PLATFORM



DO NOT ELEVATE IN WINDY CONDITIONS



DO NOT USE AS CRANE

Fall Hazards



DO NOT CLIMB ON RAILS

DO NOT sit, stand or climb on the platform guard rails. Maintain a firm footing on the platform floor at all times.

DO NOT exit the platform when elevated

Keep the platform floor clear of debris.

DO NOT fasten a fall restraint lanyard to an adjacent structure.

Ensure that all gates are properly closed and secured before operating the machine.



DO NOT EXIT PLATFORM WHEN ELEVATED

Personnel shall enter and exit the platform **only** at the Personnel Entry Gate, and only when:

- The boom is fully retracted using the Boom Extend/Retract function, and
- The platform is centered using the Platform Rotate function.

Operators must comply with employer and job site rules and governmental regulations regarding the use of personal protective equipment.

Collision Hazards



Check path before moving for equipment, materials or other obstructions.

Check path before moving for overhead obstructions.

Check path before moving for crushing hazards when holding the platform rail.

Reduce travel speed when moving the machine on slopes, when near personnel and obstacles, or when surface conditions are wet, slippery or otherwise limiting.

DO NOT operate in the path of any crane unless the controls of the crane have been locked out and/or precautions have been taken to prevent any possible collision.

Stunt driving and horseplay are PROHIBITED.

Watch for personnel and obstructions below the platform when lowering the platform.



Additional Safety Hazards

Explosion and Fire Hazards

DO NOT operate the machine in hazardous locations or locations where potentially flammable or explosive gasses or particles may be present.

Damaged Machine Hazards

Conduct a thorough pre-start inspection of the machine and test all functions before each work shift to check for damage, malfunction and unauthorized modification. Tag and remove a damaged, malfunctioning or modified machine from service. DO NOT use a damaged, malfunctioning or modified machine.

Routine maintenance must be performed by the operator before each work shift. Scheduled maintenance must be performed by a qualified service technician at scheduled intervals. Tag and remove from service any machine that has not had scheduled preventative maintenance performed.

Check that all safety and instructional decals are in place and undamaged.

Check that the operator's, safety and responsibilities manuals are present in the storage container located in the platform. All manuals must be complete, undamaged and readable.

Bodily Injury Hazards

DO NOT operate the machine when there is a hydraulic fluid or air leak. Hydraulic fluid or air under pressure can penetrate and/or burn skin.

All compartments must remain closed and secure during machine operation. Improper contact with components under any cover will cause serious injury. Only trained maintenance personnel should access compartments. The operator should only access a compartment when performing pre-operation inspection.

Weld Line to Platform Safety (if equipped)

Read, understand and follow all warnings and instructions provided with the welding power unit.

Do not connect weld leads or cables unless the welding power unit is turned off at the platform controls.

DO NOT operate unless the weld cables are properly connected.

DO NOT connect the ground lead to the platform.

Battery Safety

Burn Hazards

Batteries contain acid. Always wear protective clothing and eye wear when working with batteries.

Avoid spilling or contacting battery acid. Neutralize battery acid spills with baking soda and water.

Explosion Hazard

Keep sparks, flame and lighted tobacco away from batteries. Batteries emit explosive gas.

Electrocution Hazard

Avoid contact with electrical terminals.

Controls & Components

Component Locations

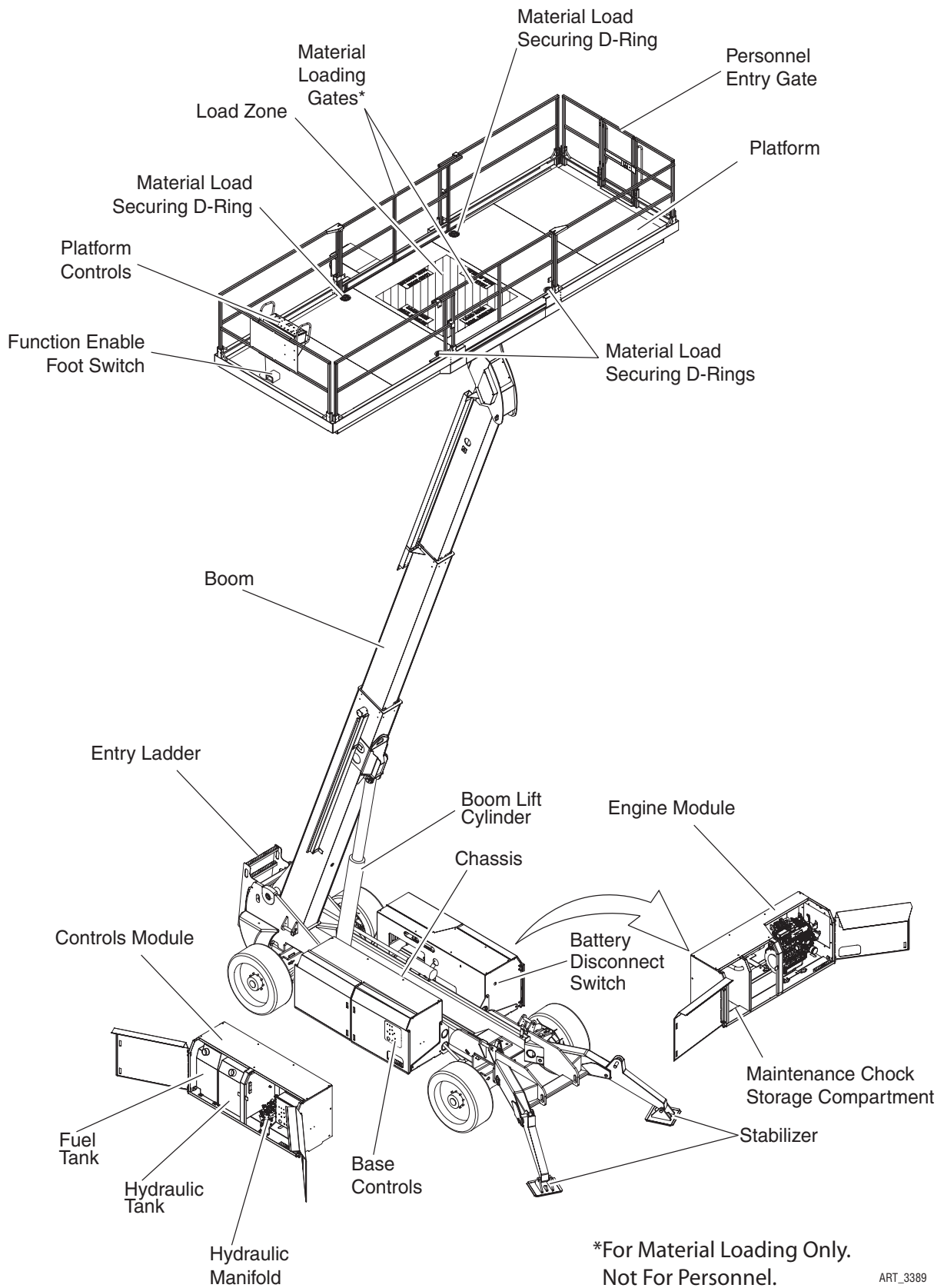

ART_3389

Platform Controls

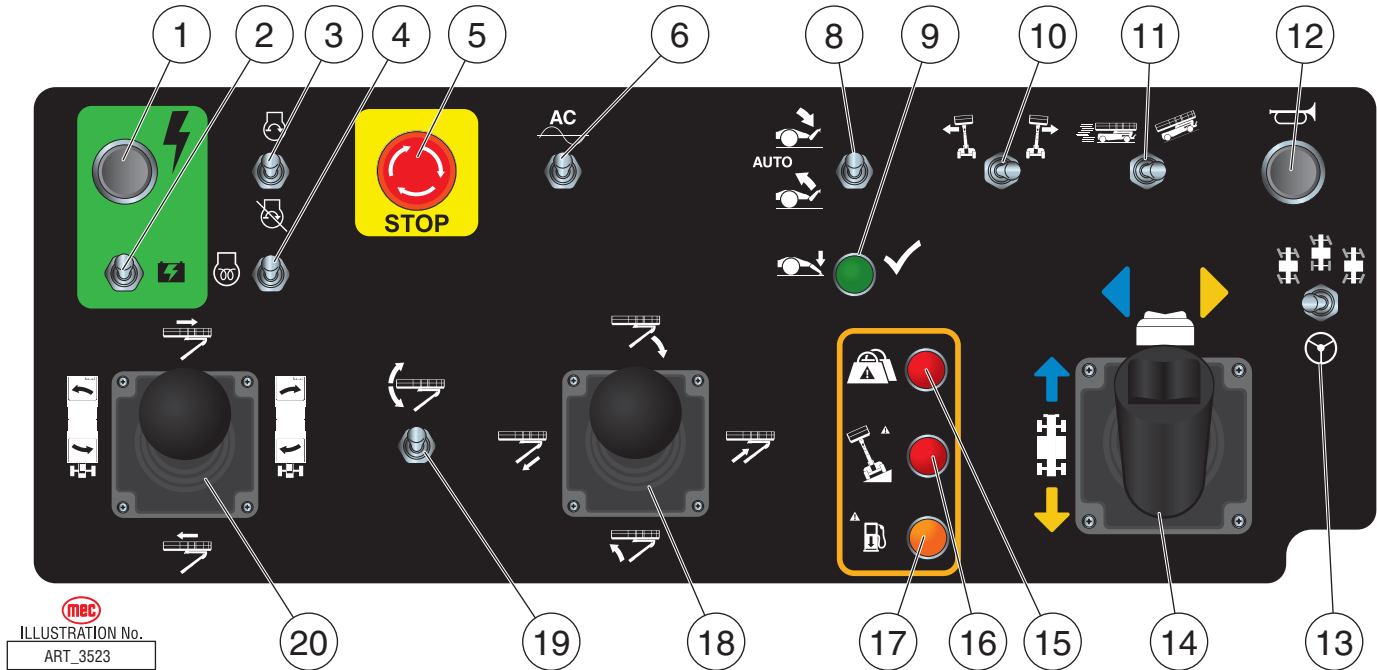

mec
ILLUSTRATION No.
ART_3523

WARNING

ALWAYS be aware of the machine's position and of your surroundings before activating any control function.

CONTROL		DESCRIPTION
1	Function Enable Button	Press and hold this button to enable boom, platform, frame level and stabilizer operations.
2	Auxiliary Power	If normal power fails, press and hold while using boom retract and boom lower functions.
3	Start/Stop Switch	Move this switch up to start engine. Press this switch down to stop engine.
4	Glow Switch	Move this switch up to activate glow plugs prior to cold starting the engine.
5	Emergency Stop Switch	Press the EMERGENCY STOP switch at any time to stop all machine functions. Turn switch <i>clockwise</i> to reset
6	Generator Switch (Optional Equipment)	Turn switch ON to engage optional AC generator. Generator switches off in any other function is enabled.
7	--	--
8	Stabilizer Switch	Move and hold this switch down until stabilizer deployment stops automatically. Move and hold this switch up to retract stabilizers.
9	Stabilizers Set Indicator Light	Green light illuminates when the stabilizers are fully deployed and the full range of boom functions are enabled.
10	Frame Level Switch	Move this switch left or right to manually adjust the level position of the frame.
11	Speed/Torque Switch	Move this switch to the left for high speed drive. Push this switch to the right for high torque drive.
12	Horn Button	Press to sound warning horn.
13	Steering Mode Switch	Use this switch to set the steering mode: Left position: Crab Steer -- All four wheel turn in the same direction. Center position: 2-Wheel Steer -- Only the front two wheels steer. Right position: 4-Wheel Steer -- The front and rear wheels steer in opposite directions.

CONTROL		DESCRIPTION	
14	Drive/Steer Control Lever	Depending on the placement of the control box and the orientation of the platform, the machine may move in unexpected directions when the Drive and Steer functions are activated. The color- and shape-coded arrows on the joystick decal correspond to similar arrow decals on the machine chassis. Be sure to check the arrows on the chassis before using the Drive or Steer functions.	
		Drive Function	Push the control lever forward or backward to drive the machine.
		Steer Function	Press the thumb switch on top of the control lever to steer left or right.
15	Overload Indicator Light	Light ON indicates too much weight on the platform. An audible alarm will sound and all machine function will stop. Remove weight from the platform to restore function and continue.	
16	Tilt Indicator Light	If this red light is illuminated, the machine is not level. Carefully retract the boom, then lower the boom, before leveling the machine, or move the machine to a firm, level surface.	
17	Low Fuel Indicator Light	If this amber light is illuminated, the fuel level is low. Refuel soon.	
18	Boom Function Control Lever	Boom Lift/Lower Function	Depress the enable button on top of the control lever, then pull the joystick backward to lift the boom. Depress the enable button on top of the control lever, then push the joystick forward to lower the boom.
		Boom Extend/Retract Function	Depress the enable button on top of the control lever, then push the control lever right to extend the boom. Depress the enable button on top of the control lever, then push the control lever left to retract the boom.
19	Platform Level Switch	Press this switch up to manually level the rear of the platform upward. Press this switch down to manually level the rear of the platform downward.	
20	Platform Function Control Lever	Platform Slide Forward/Rearward Function	Press the enable button on top of the control lever, then push the control lever forward to slide the platform forward along the platform support beam. Press the enable button on top of the control lever, then pull the control lever backward to slide the platform rearward along the platform support beam.
		Platform Rotate Function	Press the enable button on top of the control lever, then push the control lever left to rotate the platform counterclockwise. Press the enable button on top of the control lever, then push the control lever right to rotate the platform clockwise. The Platform Rotate function will stop when the platform reaches its detent center position. To continue to rotate the platform, return the joystick to the neutral position, then push the joystick to rotate the platform in the desired direction.

Base Controls

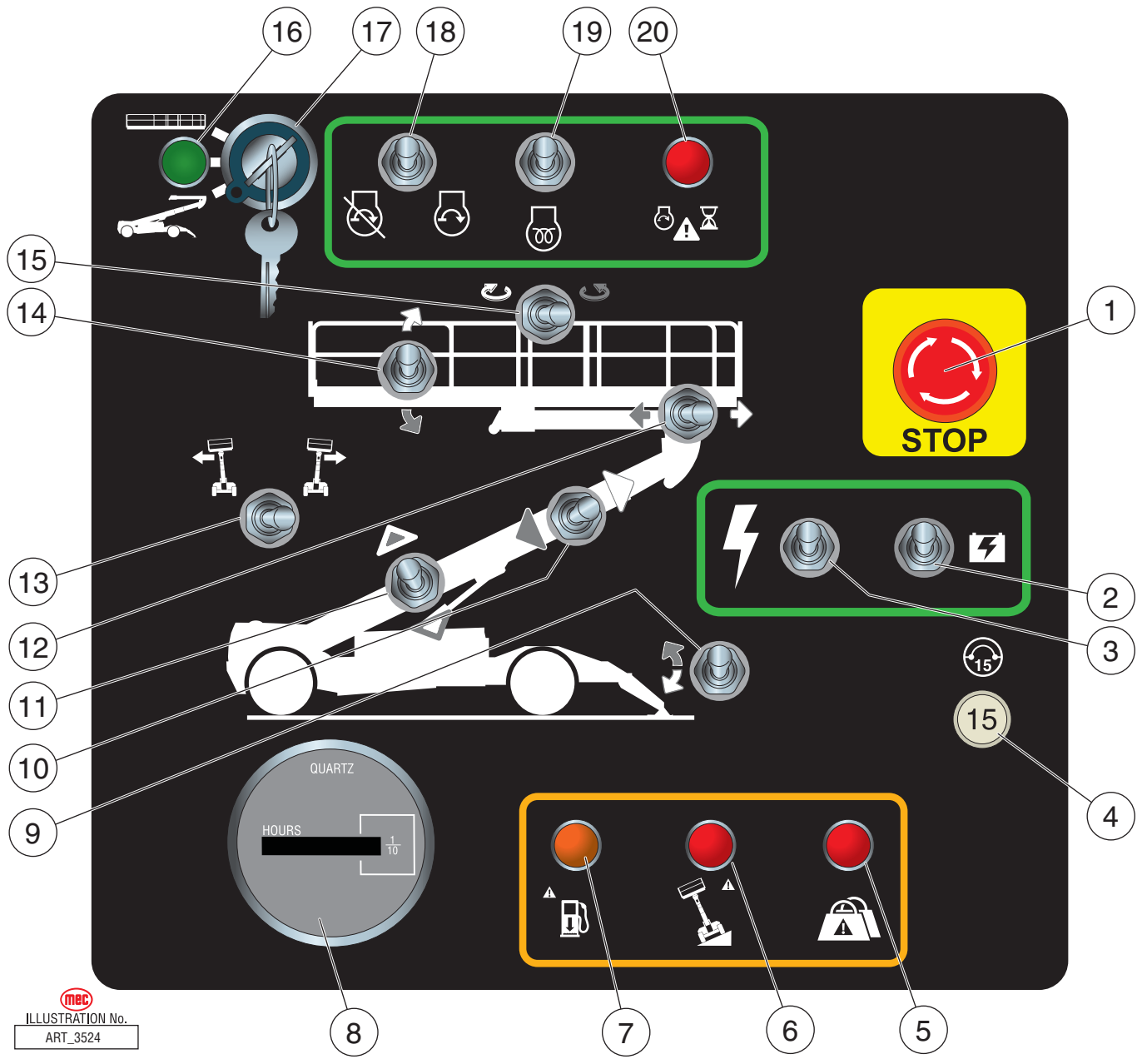

mecc
ILLUSTRATION No.
ART_3524

! WARNING

ALWAYS be aware of the machine's position and of your surroundings before activating any control function.

CONTROL		DESCRIPTION	
1	Emergency Stop Switch	Press the EMERGENCY STOP switch at any time to stop all machine functions. Turn switch <i>clockwise</i> to reset	
2	Auxiliary Power Switch	If normal power fails, press and hold while using boom retract and boom lower functions.	
3	Function Enable Switch	Press and hold this switch to enable boom, platform, frame level and stabilizer operations. Press down to operate the controls at slow speed. Press up to operate the controls at higher speed.	
4	Circuit Breaker	Trips when there is excessive electrical load. Push to reset.	
5	Overload Indicator Light	Light ON indicates too much weight on the platform. An audible alarm will sound and all machine function will stop. Remove weight from the platform to restore function and continue.	
6	Tilt Indicator Light	When this red light is illuminated, the machine is not level. Carefully retract the boom, then lower the boom, before leveling the machine, or move the machine to a firm, level surface.	
7	Low Fuel Indicator Light	When this amber light is illuminated, the fuel level is low. Refuel soon.	
8	Hour Meter	Indicates total elapsed time of machine operation.	
9	Stabilizer Switch	Move and hold down until automatic stabilizer deployment stops automatically. Move and hold up to retract stabilizers.	
10	Boom Extend/Retract	Move this switch right to extend the boom. Move this switch left to retract the boom.	
11	Boom Lift/Lower	Move this switch up to lift the boom. Move this switch down to lower the boom.	
12	Platform Slide Forward/Rearward	Move this switch right to move the platform forward along the platform support beam. Move this switch left to move the platform rearward along the platform support beam.	
13	Frame Level Switch	Move this switch left to manually adjust the level position of the frame to the left. Move this switch right to manually adjust the level position of the frame to the right.	
14	Platform Level Switch	Move this switch up to manually level the rear of the platform upward. Move this switch down to manually level the rear of the platform downward.	
15	Platform Rotate Switch	Move this switch left to rotate the platform clockwise. Move this switch right to rotate the platform counterclockwise. The Platform Rotate function will stop when the platform reaches its detent center position. To continue to rotate the platform, return the switch to the neutral position, then push the switch to rotate the platform in the desired direction.	
16	Power On Indicator Light	When this green light is illuminated, the Selector Switch (#16) is set to either platform or chassis. This light is not illuminated when the key is turned to the center (off) position.	
17	Selector Switch	PLATFORM	Select to operate from the platform control panel.
		BASE	Select to operate from the base control panel.
		OFF	Select to stop operation from either control panel.
18	Start/Stop Switch	Push switch up to start engine. Push switch down to stop engine.	
19	Glow Switch	Press this switch up to activate glow plugs prior to starting.	
20	Starter Time-out Indicator	When this red light is illuminated, the starter circuit is temporarily disabled. The starter circuit times out if the starter is run continuously for 15 seconds without the engine starting. The starter functions resets after 30 seconds.	

Workplace Inspection

DO NOT operate this machine until you have read and understood this manual, have performed the Workplace Inspection, Pre-Start Inspection and Routine Maintenance, and have completed all the test operations detailed in the Operating Instructions section.

Inspect the workplace and determine whether the workplace is suitable for safe machine operation. Do this before moving the machine to the workplace.

Be sure the lift is the correct machine for the job.

Be aware of workplace conditions, and continue to watch for hazards while operating the machine.

Workplace Inspection

Before operating the machine, check the workplace for all possible hazards, including but not limited to:

- drop-offs or holes, including those concealed by water, ice, mud, etc.
- sloped, unstable or slippery surfaces
- bumps, surface obstructions and debris
- overhead obstructions and electrical conductors
- other objects or equipment
- hazardous locations and atmospheres
- inadequate surface and support to withstand all load forces imposed by the machine
- wind and weather conditions
- the presence of unauthorized personnel
- other possible unsafe conditions

Operating Instructions & Function Tests

DO NOT operate this machine until you have read and understood this manual, have performed the Workplace Inspection, Pre-Start Inspection and Routine Maintenance, and have completed all the test operations detailed in the Operating Instructions section.

This section provides instructions and tests for each function of machine operation. Follow all safety rules and instructions. The operator must conduct inspections and a Functions Test of the machine before each work shift to check that all machine systems are working properly.

Test the machine on a firm level surface with no debris, drop-offs, potholes or overhead obstructions. Perform each step outlined in this section.

This machine shall only be operated by trained and authorized personnel. If multiple operators use this machine, all must be trained, qualified and authorized to use it. New operators must perform a Pre-Start Inspection and Functions Test prior to operating the machine.

Operators must comply with all employer and job site rules and governmental regulations regarding the use of personal protective equipment – see *Fall Protection* on page 3.

DO NOT use a machine that is malfunctioning. If any function does not perform as described, tag the machine and remove for repair by a qualified service technician. After repairs are completed, a Pre-Start Inspection and Functions Test must be performed before using the machine.

Prestart

- Perform *Prestart Inspection* (see page 37).
- Check Emergency Stop Switches at both the base and platform controls – turn clockwise to reset.



ART_3353

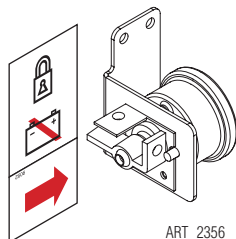

ART_2356

- Check Battery Disconnect Switch outside the front end of the Engine Module. Must be in ON position.

Starting Engine from Base Controls

Be sure that the upper and lower EMERGENCY STOP Switches are reset.

- **Lower Control Box:** Turn Key Switch to CHASSIS.



ART_3345

- Move the Start/Stop switch to the right to start. Release the switch when the engine starts.

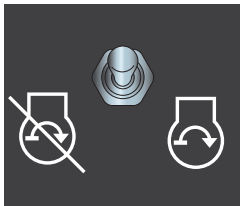

ART_3344

- **Cold Start:** Move and hold the Glow Switch up as indicated in the Preheat table.
- With the Glow switch held up, press and hold the Start/Stop switch to the right until the engine starts.
- Release both switches once the engine starts.



ART_3343

Preheat Table

Ambient Temperature	Preheat Time
Above 50°F (10°C)	5 Seconds
50°F to 23°F (10°C to -5°C)	10 Seconds
Below 50°F (-5°C)	20 Seconds
20 Seconds = Limit of Continuous Use	

- To protect the starter motor, power will cut off to the starter circuit when the starter motor has run continuously for 15 seconds without starting the engine. The Starter Circuit Cutout indicator light will turn on and power to the starter circuit will cut out for 30 seconds.



ART_3342

Starting Engine from Platform Controls

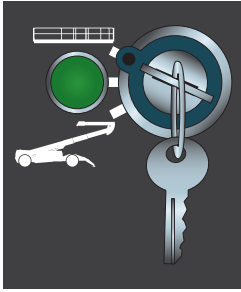

ART_3371

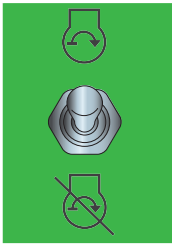

ART_3355



ART_3357

- **Lower Control Box:** Turn the Key Switch to PLATFORM.
- **Platform Control Box:** Move the Start/Stop switch UP to start. Release the switch when the engine starts.
- **Cold Start:** Move and hold the Glow Switch up as indicated in the Preheat table.
- With the Glow switch held up, press and hold the Start/Stop switch UP until the engine starts.
- Release both switches once the engine starts.

Preheat Table

Ambient Temperature	Preheat Time
Above 50°F (10°C)	5 Seconds
50°F to 23°F (10°C to -5°C)	10 Seconds
Below 50°F (-5°C)	20 Seconds
20 Seconds = Limit of Continuous Use	

- To protect the starter motor, power will cut off to the starter circuit when the starter motor has run continuously for 15 seconds without starting the engine. The Starter Circuit Cutout indicator light will turn on at the Base Control panel and power to the starter circuit will cut out for 30 seconds.

Base Controls Operation and Test

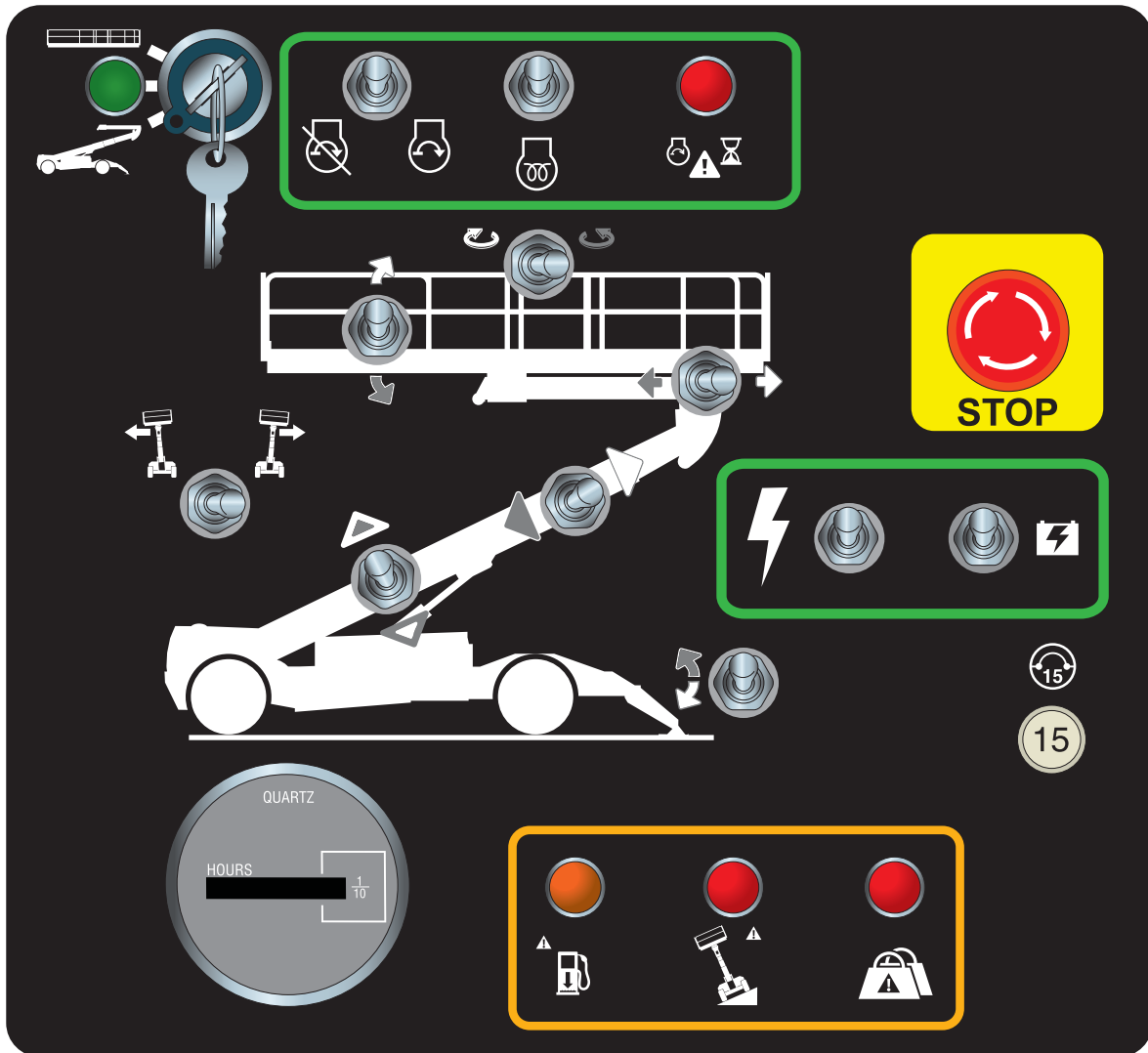

mec
ILLUSTRATION No.
ART_3527

! WARNING

Check the area above and around the machine for obstructions before operating the machine. The machine must have space to allow full elevation of platform and full horizontal extension of the boom.



ART_3353

Emergency Stop

- Press the Emergency Stop Switch at any time to stop all machine functions.
- Turn switch *clockwise* to reset.



ART_3345

Select BASE Operation

- Turn the Selector Key Switch to BASE.

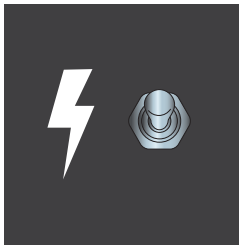

ART_3339

Function Enable

- Press and hold this switch to enable and operate machine functions from the base controls.
- Press down to operate the controls at slow speed.
- Press up to operate the controls at higher speed.
- Releasing this switch will disable machine functions.



Do not elevate the platform if the machine is not on a firm level surface.

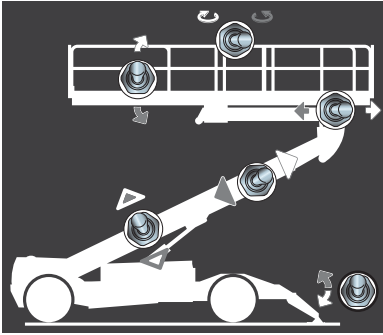

ART_3369

Base Control Boom/Platform Functions

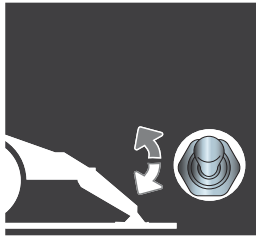

ART_3347

Stabilizer Deploy/Retract

- Move and hold the Stabilizer Deploy/Retract switch down to deploy the stabilizers. Continue to hold the switch down until the stabilizers automatically stop.

Note: Stabilizer deployment first automatically levels the frame, then deploys the stabilizers.

Test Operation

- Press and hold the Function Enable switch.
- Hold switch down until stabilizer deployment stops.
- Releasing the button will stop deployment.
- Pressing the Emergency Stop Switch will stop deployment.

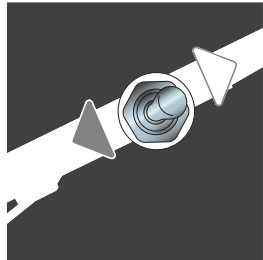

ART_3349

Boom Extend/Retract

When the Stabilizers are not deployed, the Boom Extend function will cut off after extending approximately 8.5 feet (2.6 m).

- Move and hold the Extend/Retract switch on the base control panel to extend or retract the boom.

Test Operation

- Press and hold the Function Enable switch.
- Retract stabilizers. Extend boom until it stops. Extension should stop after approximately 8.5 feet (2.6 m).
- Retract the boom completely. Deploy stabilizers.
- Extend boom until it stops. Boom should extend to maximum length.
- Retract the boom until it stops. Boom should retract to minimum length.
- Releasing the switch will stop boom extension or retraction.
- Pressing the Emergency Stop Switch will stop boom extension or retraction.

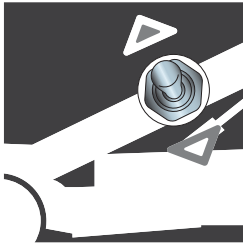

ART_3348

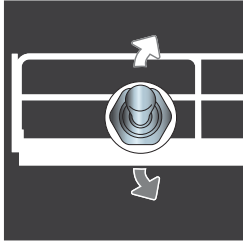

ART_3350

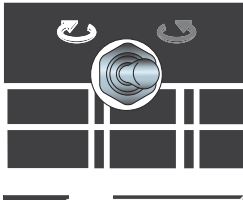

ART_3351

Boom Lift/Lower

- Press and hold the Boom Lift/Lower switch on the base control panel to lift or lower the boom.

Test Operation

- Press and hold the Function Enable switch.
- Raise the boom until it stops. Boom should lift to full height.
- Lower the boom until it stops. Boom should rest on the chassis.
- Releasing the switch will stop Boom Lift/Lower function.
- Pressing the Emergency Stop Switch will stop boom lift/lower function.

Platform Level

The platform will automatically level as the boom is lifted or lowered. The Platform Level function allows manual level adjustment of the platform.

- Press and hold the Platform Level switch on the base control panel to manually adjust the level of the platform.
- Platform Level power is disabled upon exceeding 5° out of level. Power is allowed only to the direction that returns the platform toward level.

Test Operation

- Press and hold the Function Enable switch.
- Push the switch up and down. The platform level should change accordingly.
- Releasing the switch will stop platform level function.
- Pressing the Emergency Stop Switch will stop platform level function.

Platform Rotate

- Press and hold the Platform Rotate switch on the base control panel to rotate the platform.

Test Operation

- Press and hold the Function Enable switch.
- Push the switch left and right. The platform should rotate accordingly.
- Releasing the switch will stop platform rotate function.
- Pressing the Emergency Stop Switch will stop platform rotate function

Note: The Platform Rotate function will stop when the platform reaches its detent center position. To continue to rotate the platform, return the switch to the neutral position, then push the switch to rotate the platform in the desired direction.

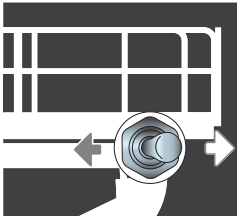

ART_3352

Platform Slide Forward/Reverse

- Press and hold the Platform Slide switch on the base control panel to slide the platform along the platform support beam.

Test Operation

- Press and hold the Function Enable switch.
- Push the switch left and right. The platform should move along the platform support beam accordingly.
- Releasing the switch will stop Platform Slide function.
- Pressing the Emergency Stop Switch will stop Platform Slide function.

Chassis Level Switch

Use this control to manually change the level of the chassis. This function is disabled when the boom is elevated.

Note: This function is performed automatically when deploying the stabilizers.

Test Operation

- Press and hold the Function Enable switch.
- Push the switch left or right. The chassis of the machine will move in the direction the switch is pushed.

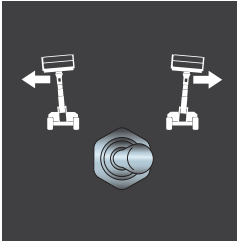

ART_3354

Tilt Indicator Light

Light ON and alarm sounding indicates an unsafe condition.

- STOP. The machine is not level. Carefully retract the boom, then lower the boom. Level the machine, or move the machine to a firm, level surface.

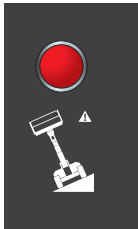

ART_3337b

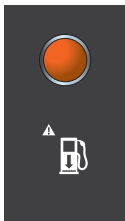

ART_3337

Low Fuel Indicator Light

Light ON indicates a low-fuel alert condition.

- Refuel soon.



ART_3528

Overload Light and Alarm

- Light ON indicates too much weight on the platform.
- An audible alarm will sound and all machine function will stop.
- Remove weight from the platform to restore function and continue.

Platform Control Operation and Test

Entering The Platform

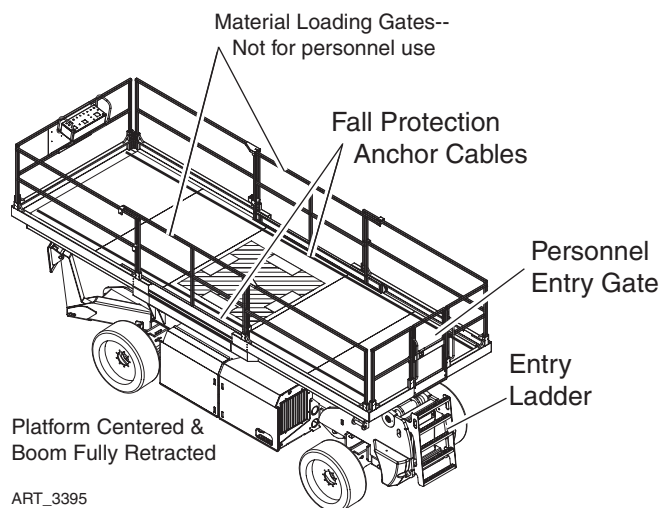

Personnel shall enter and exit the platform only at the Personnel Entry Gate, and only when:

- The boom is fully retracted using the Boom Extend/Retract function, and
- The platform is centered using the Platform Rotate function.

Note: The Platform Rotate function will stop when the platform reaches its center position. To continue to rotate the platform, return the joystick to the neutral position, then push the joystick to rotate the platform in the desired direction.

The Personnel Entry Gate is spring-loaded and latches itself when released. Check that it is securely closed and latched before operation.

Fall Protection

Maximum 4 Occurrences

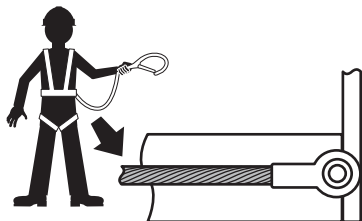

Personal fall protection equipment (PFPE) is required when operating this machine.

All PFPE must comply with employer and job site rules and applicable governmental regulations, and must be inspected and used in accordance with the PFPE manufacturer's instructions.

ALWAYS wear approved fall protection, properly attached to an anchor cable, when operating the machine.

Platform Control Panel

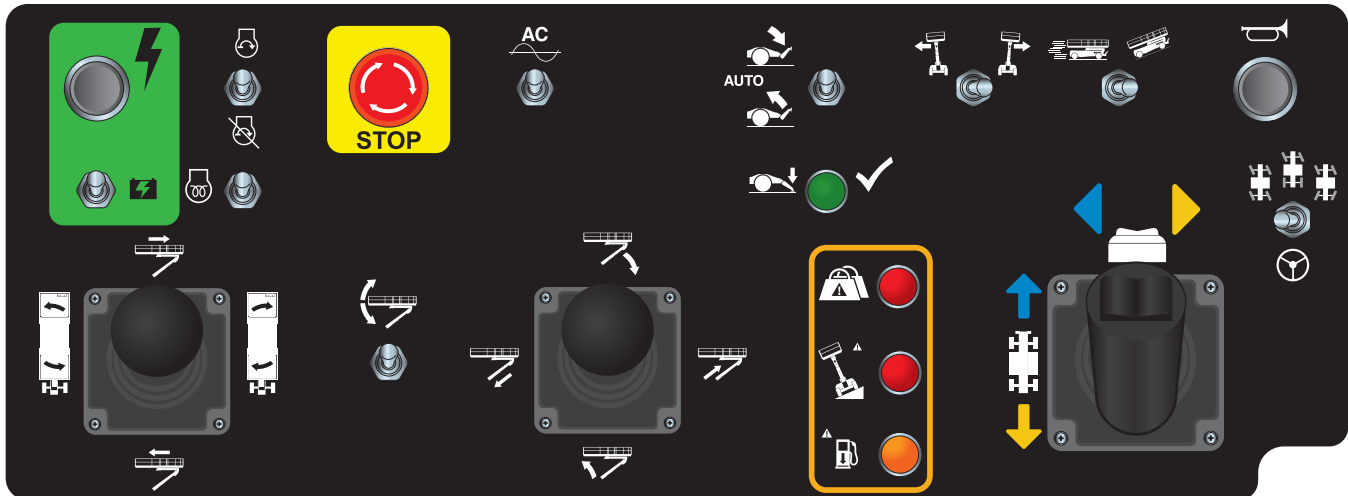

MBC
ILLUSTRATION No.
ART_3526

IMPORTANT—Before moving, check that the route of travel to be taken is clear of persons, obstructions, debris, holes, and drop offs, and is capable of supporting the machine.

Function Enable At Platform Controls

There are separate Function Enable features for drive/steering and lift functions.

Drive Function Enable

Drive and steer functions are enabled by squeezing the trigger at the front of the drive control handle.

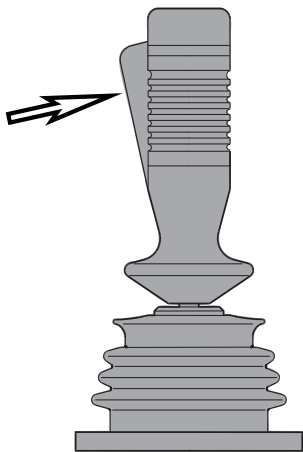

ART_3374

Lift Function Enable

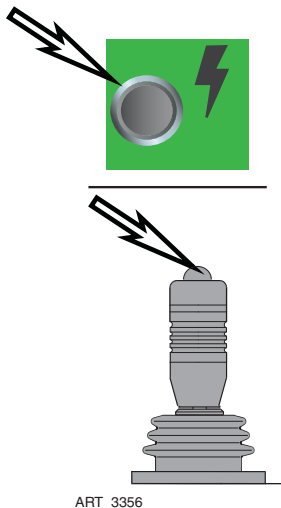

ART_3356

Lift functions (all boom, platform, chassis level and stabilizer operations) are enabled by pressing and holding the button on top of either the Boom or Platform control levers, or the green Enable button at the top left of the Platform Control Station. This allows the use of multiple boom and platform functions if desired.

Platform Operations Test



ART_3353

Emergency Stop

- Press the EMERGENCY STOP switch at any time to stop all machine functions.
- Turn switch *clockwise* to reset.



WARNING

Activation of the EMERGENCY STOP switch will apply brakes immediately. This may cause unexpected platform movement as the machine comes to a sudden stop. Brace yourself and secure objects on the platform during operation of machine.

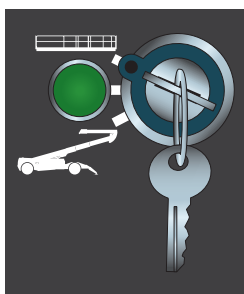

ART_3371

Select PLATFORM Operation

- **Base Controls:** Turn the selector switch to PLATFORM.

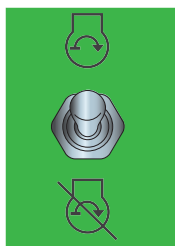

ART_3355

Operate from Platform

- Enter the platform through the Personnel Entry Gate. Close and secure the entry.
- Press the Start/Stop switch UP to start. Release the switch when the engine starts.



ART_3359

- Press the Horn Button to verify proper operation.

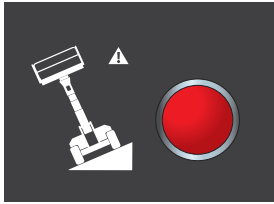

ART_3363b

Tilt Indicator Light

Light ON and alarm sounding indicates an unsafe condition.

- STOP. The machine is not level. Carefully retract the boom, then lower the boom. Level the machine, or move the machine to a firm, level surface.

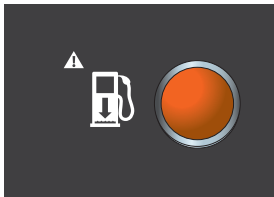

ART_3363

Low Fuel Indicator Light

Light ON indicates a low-fuel alert condition.

- Refuel soon.

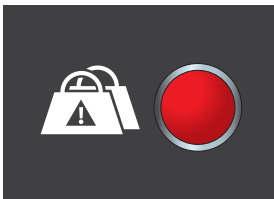

ART_3529

Overload Light and Alarm

- Light ON indicates too much weight on the platform.
- An audible alarm will sound and all machine function will stop.
- Remove weight from the platform to restore function and continue.

Drive Control Lever Operation

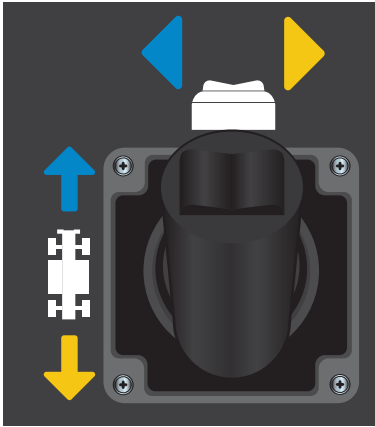

ART_3366

Depending on the placement of the control box and the orientation of the platform, the machine may move in unexpected directions when the Drive and Steer functions are activated. The color- and shape-coded arrows on the joystick decal correspond to similar arrow decals on the machine chassis. Be sure to check the arrows on the chassis before using the Drive or Steer functions.

- Drive Function speed is proportional and is controlled by the positional of the control lever. The further it is moved from the neutral (center) position, the faster the speed will be.
- When the boom is elevated beyond an 8° angle or extended beyond 8 inches (0.2 m), the maximum drive speed is reduced to 0.5 mph (0.8 km/h). Drive function speed is still fully proportional to the position of the drive control handle.
- The control lever returns to the neutral (center) position when released.
- Steering Function is not proportional.

Test Operation

- Drive: Squeeze the enable trigger, then move the control lever in the desired direction of movement. The further it is moved from the neutral (center) position, the faster the speed will be.
- Stop: Return the control lever to the neutral (center) position. Releasing the control lever will also stop the machine.
- Extend the boom approximately 3 feet (1 m), then drive the machine. Speed should be reduced significantly from the fully-retracted, fully-lowered speed. Retract the boom.
- Elevate the boom approximately 15°, then drive the machine. Speed should be reduced significantly from the fully-retracted, fully-lowered speed. Lower the boom.
- Steering: Squeeze the enable trigger, then press the thumb switch on top of the control lever to steer in the desired direction.

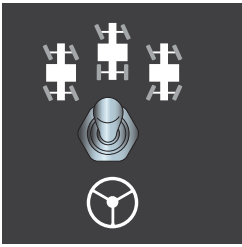

ART_3362

Steering Mode

Three steering modes are available: Crab Steer, 2-Wheel Steer and 4-Wheel Steer.

To return to 2-Wheel steering after using the Crab Steer or 4-Wheel Steer modes, center the rear wheels, then switch to 2-wheel steer mode.

Test Operation

- Set Steering mode to the left position: Crab Steer. Squeeze the enable trigger, then press the thumb switch on top of the control lever. All four wheels should turn in the same direction. Return the wheels to the centered position.
- Set Steering mode to the center position: 2-Wheel Steer. Squeeze the enable trigger, then press the thumb switch on top of the control lever. Only the front two wheels should turn. Return the wheels to the centered position.
- Set Steering mode to the right position: 4-Wheel Steer. Squeeze the enable trigger, then press the thumb switch on top of the control lever. The front and rear wheels should turn in opposite directions. Return the wheels to the centered position.

Boom & Platform Functions

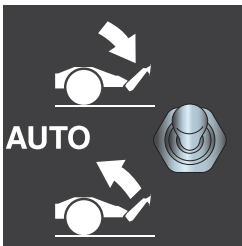

ART_3361

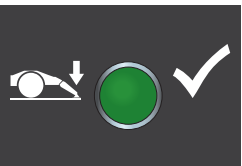

ART_3474

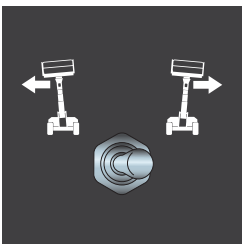

ART_3354

Stabilizer Deploy/Retract

- Press and hold the Stabilizer Deploy/Retract switch to deploy the stabilizers. Continue to hold the switch down until the stabilizers automatically stop and the green indicator light illuminates.

Note: Stabilizer deployment first automatically levels the frame, then deploys the stabilizers.

Test Operation

- Press and hold the Function Enable button.
- Continue to hold switch down until stabilizer deployment stops.
- The green Stabilizers Set indicator light will illuminate on the Platform Control box when the stabilizers are fully deployed. This indicates that full boom extension is enabled.
- Releasing the button will stop deployment.
- Pressing the Emergency Stop Switch will stop deployment.

Chassis Level Switch

Use this control to manually change the level of the chassis. This function is cut out when the boom is elevated.

Note: This function is performed automatically when deploying the stabilizers.

Test Operation

- Press and hold the Function Enable button.
- Push the switch left or right. The chassis of the machine will move in the direction the switch is pushed.

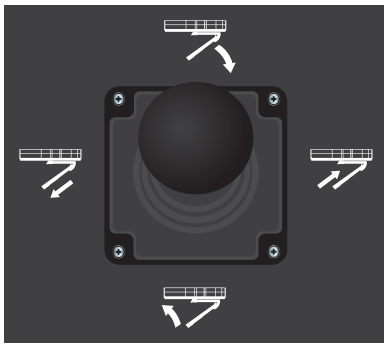

ART_3370

Boom Functions Control Lever

This control lever controls the Boom Extend/Retract and the Boom Lift/Lower functions. The control lever is fully proportional for both functions.

These functions may be enabled by pressing the button on top of the control lever.

When the stabilizers are not deployed, boom extension is limited to approximately 8.5 ft. (2.6 m). Deploying the stabilizers allows the machine to reach full extension and elevation.

Test Operation

To test the Boom Extend/Retract function; Extension cutout function:

- With the stabilizers retracted, press and hold the Function Enable button.
- Push and hold the joystick to the right until the boom stops extending. The boom should extend approximately 8.5 ft. (2.6 m), then stop.
- Push and hold the joystick to the left to retract the boom completely.
- Deploy the stabilizers.
- Push and hold the joystick to the right until the boom reaches full extension.
- Push and hold the joystick to the left to retract the boom.

To test the Boom Lift/Lower function:

- Press and hold the Function Enable button.
- Pull the joystick back to lift the boom. Lift the boom completely.
- Push the joystick forward to lower the boom. Lower the boom to its stowed position.

Platform Level Switch

The Platform Level switch manually adjusts the angle of the platform support beam.

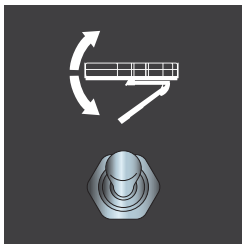

ART_3364

Test Operation

The Platform Level function is controlled automatically as the boom is raised and lowered.

To manually level the platform:

- Press and hold the Function Enable button.
- Push the Platform Level switch up or down to adjust the position of the platform.
- Platform Level power is disabled upon exceeding 5° out of level. Power is allowed only to the direction that returns the platform toward level.

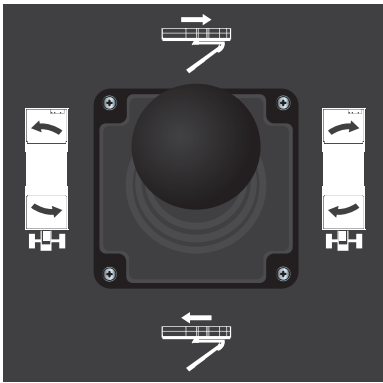

ART_3365

Platform Functions Control Lever

The Platform Functions control lever controls the Platform Slide Forward/Reverse and Platform Rotate functions. The control lever is fully proportional for both functions. These functions may be enabled by pressing the button on top of the control lever.

Test Operation

To test the Platform Slide Forward/Reverse function:

- Press and hold the Function Enable button.
- Push the control lever up to slide the platform forward.
- Push the control lever down to slide the platform rearward.

To test the Platform Rotate function:

- Press and hold the Function Enable button.
- Push the control lever left to turn the platform counterclockwise.
- Push the control lever right to turn the platform clockwise.

Note: The Platform Rotate function will stop when the platform reaches its center position. To continue to rotate the platform, return the joystick to the neutral position, then push the joystick to rotate the platform in the desired direction.

Shutdown Procedure

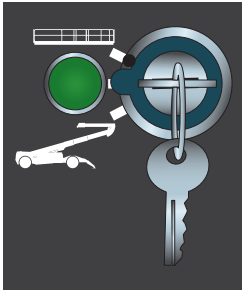

ART_3375

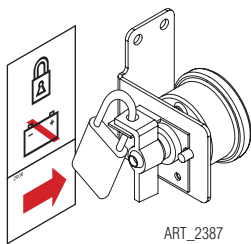

ART_2387

- When finished with the machine, place the platform in the stowed position.
- Park the machine on a level surface.
- Turn the Selector Key Switch to the OFF position and remove the key to prevent unauthorized use.
- Carefully exit the platform using a constant three (3) point dismount/grip.
- Turn the Battery Disconnect Switch to the OFF position.

Note: Leaving the Battery Disconnect Switch in the ON position for an extended time will drain the battery.

- Always put the switch in OFF position when leaving the machine at the end of the work day.
- Put a padlock on the Battery Disconnect Switch to prevent unauthorized operation.

Emergency Lowering System



If the control system fails while the platform is elevated, use the emergency lowering procedure to safely lower the platform.

Do not climb down the boom assembly or exit the platform.

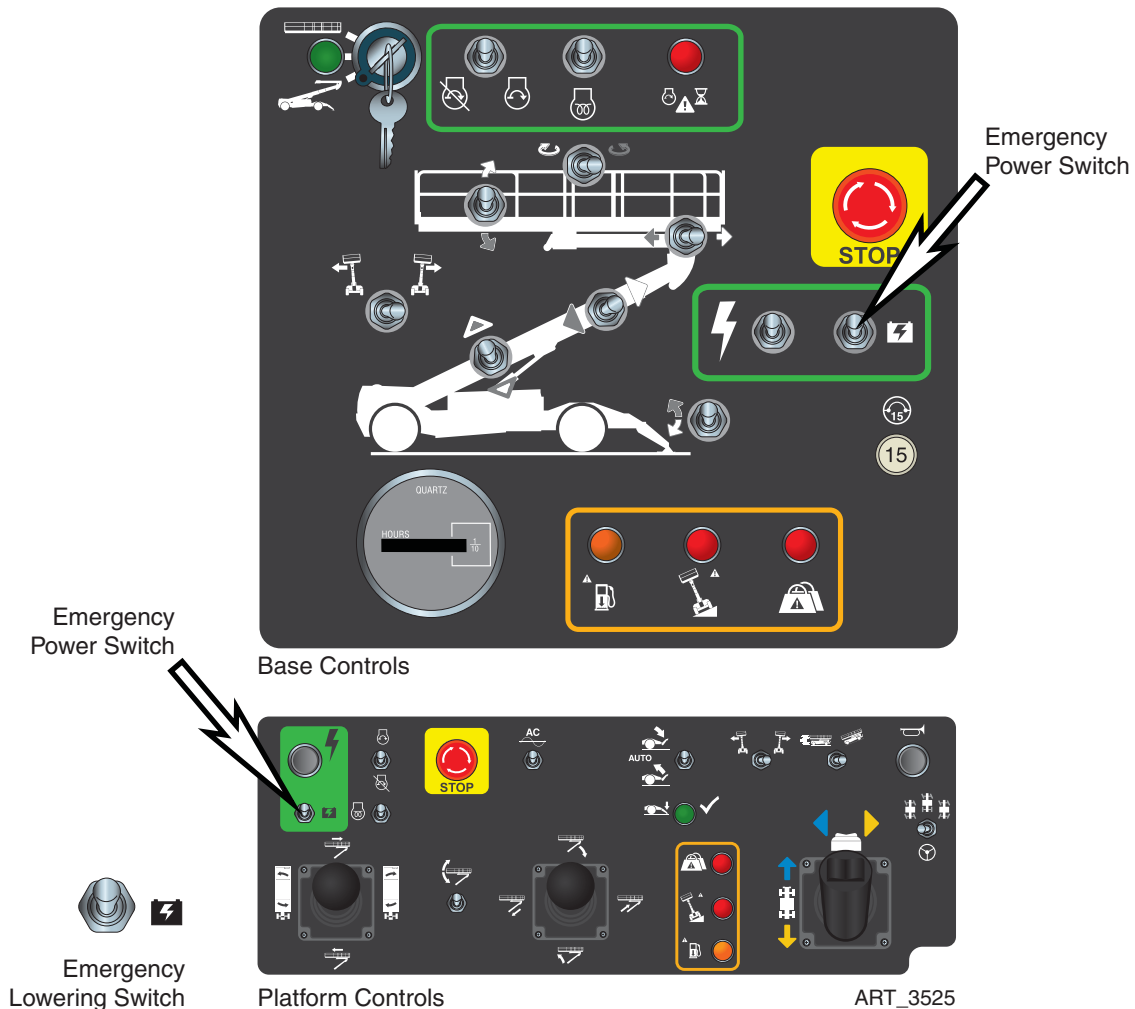

The Emergency Lowering System is used to lower the platform in case of power failure. To lower the platform, activate the Emergency Power Switch to run the Emergency Down auxiliary hydraulic pump.

This function uses battery power from the auxiliary battery to lower the platform.

- Push and hold the Auxiliary Power switch, then use the Boom Extend/Retract function to retract the boom.
- Continue to hold the Auxiliary Power switch, then use the Boom Lift/Lower function to lower the boom.

Note: The Emergency Lowering System is disabled when the engine is running.

Note: The Emergency Power switch serves as an enable switch. It is not necessary to use the primary function enable switch.

Fold Down Platform Railings

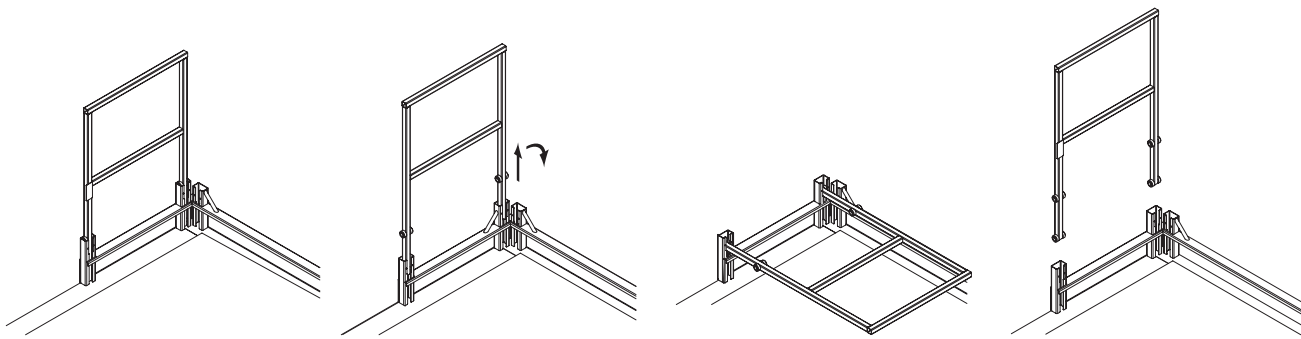

ART_3382

The TITAN Boom™ uses a pinless guard rail system. After removing the loading gates, lift the guard rail section and pivot to stow, or lift further to remove the rail.

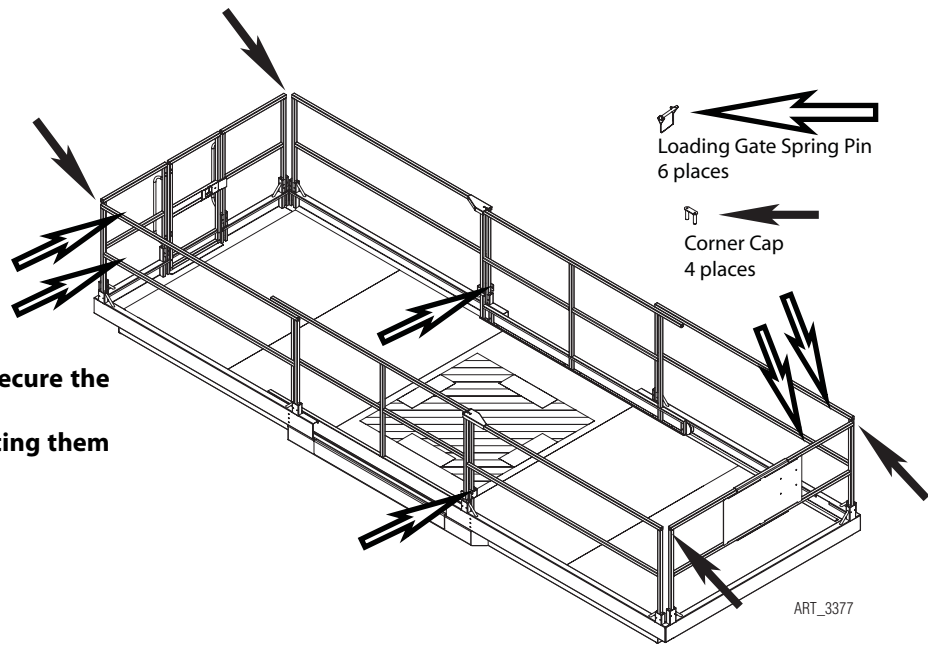

ART_3377

- 1** Remove the spring pins that secure the loading gates. Remove the corner caps by lifting them straight up.

- 2** Slide the loading gates away from the load area, then pivot away from the guard rails. Lay the gates in the front section of the platform.

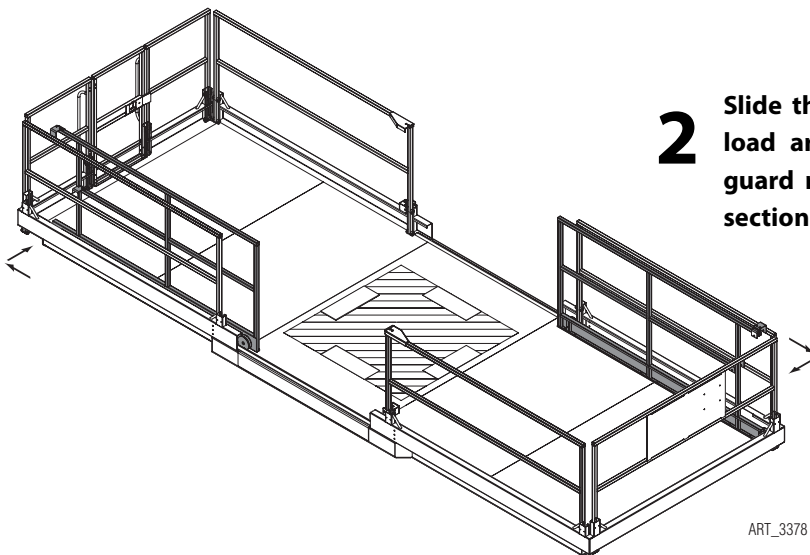

ART_3378

continued...

Fold Down Rails (continued)

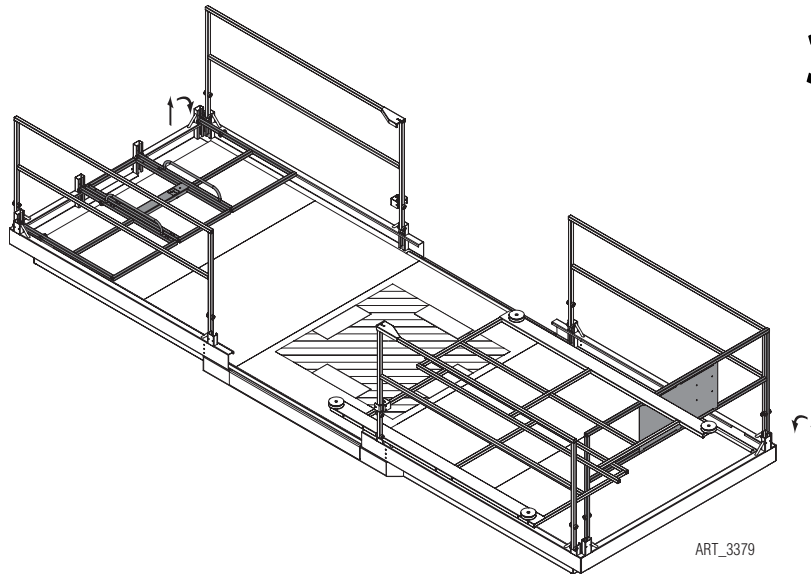

3 Lift and pivot the end sections to the stowed position.

4 Lift and pivot the side sections to the stowed position.

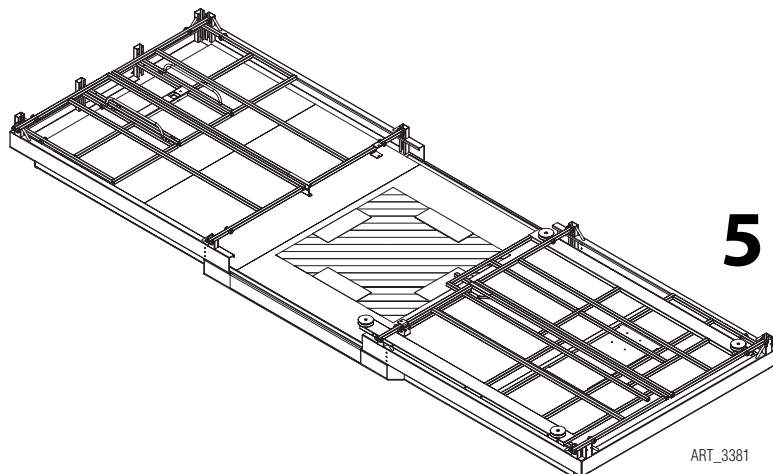
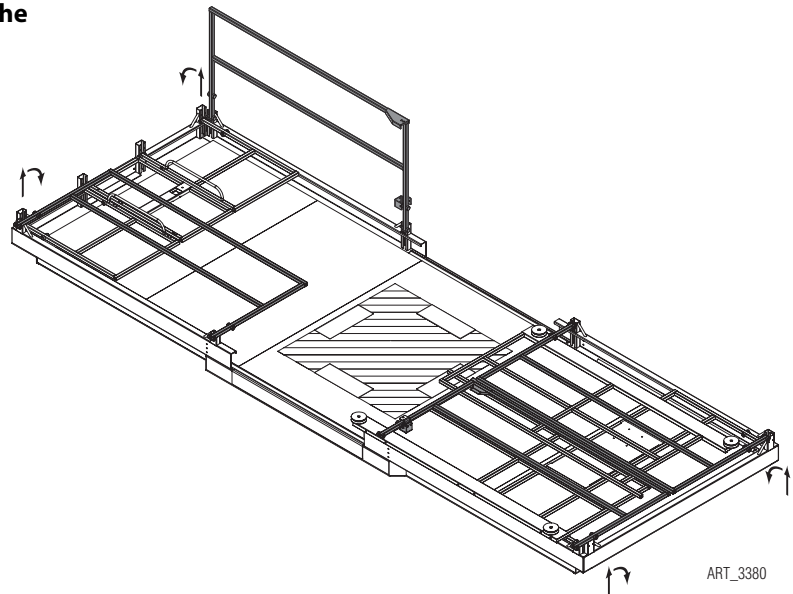

5 Guard rails are stowed.

To return the machine to normal operation mode:

- Lift all rails into their upright position, then push down so secure them
- Install the loading gates, spring pins and corner caps
- Position the platform control box on the front rail.

DO NOT use the machine until all gates and guard rails are in position and properly secured.

Platform Capacity & Material Loading



- DO NOT exceed the Maximum Platform Capacity, including persons, of 1810 kg.**
- DO NOT exceed the Maximum Platform Capacity Outside Load Zone of 450 kg.**
- DO NOT exceed the maximum material load zone capacity of 1360 kg located and secured in the load zone only.**
- The center of mass (CG) of large material must lie within the designated load zone marked on the platform floor.**
- Personnel SHALL NOT enter or exit the platform through the loading gates.**
- Personnel must stand clear of open gates and moving material loads while loading.**

The TITAN Boom™ is equipped with 2 loading gates for the assisted loading of heavy materials.

To load palletized or other large material:

- Remove the single spring pin the holds the loading gate in the closed position.
- Ensure that the gate is fully open before loading the machine.
- Load material onto the platform, taking care to keep the center of mass (CG) in the designated load zone marked on the platform floor.
- Close the loading gate and secure it with the spring pin.
- Secure the load with straps tied to the tie-down points before moving the machine.

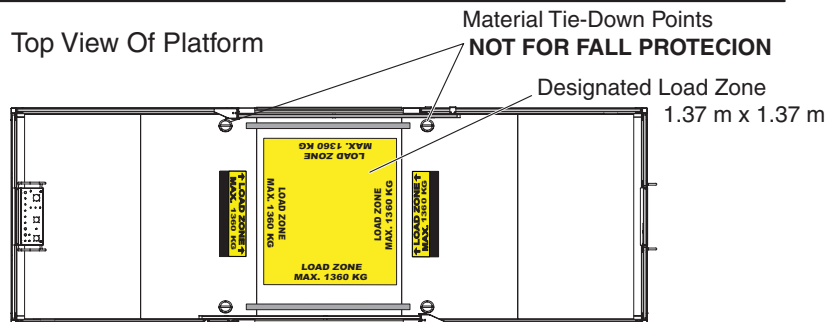
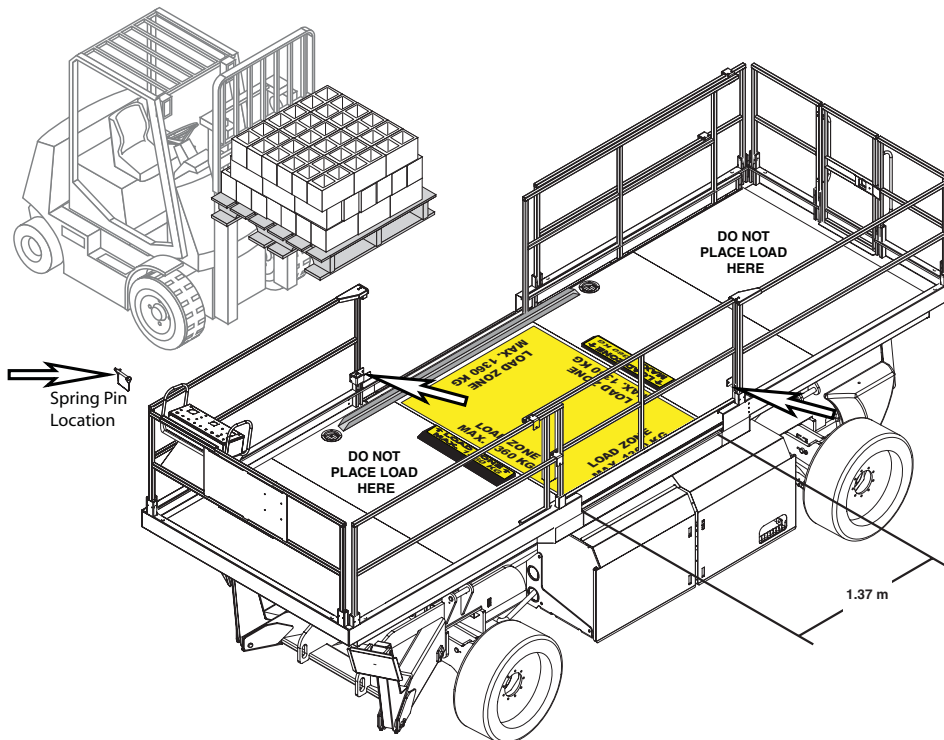

ART_3530

Machine Inspections and Maintenance

DO NOT operate this machine until you have read and understood this manual, have performed the Workplace Inspection, Pre-Start Inspection and Routine Maintenance, and have completed all the test operations detailed in the Operating Instructions section.

The operator must conduct a Pre-Start Inspection of the machine and test all functions before each work shift to check for damage, malfunction and unauthorized modification.

Tag and remove a damaged, malfunctioning or modified machine from service. DO NOT use a damaged, malfunctioning or modified machine.

Use the Pre-Start Inspection to determine what Routine Maintenance is required. The operator may perform only the routine maintenance items specified in this manual.

IMPORTANT— Scheduled maintenance inspection checklists are included in this manual for use only by qualified service technicians. Only qualified service technicians may perform repairs to the machine. After repairs are completed, the operator must perform a Pre-Start Inspection before proceeding to the Functions Test.



Hydraulic fluid under pressure can penetrate and burn skin, damage eyes, and may cause serious injury, blindness, and death. Repair leaks immediately. Fluid leaks under pressure may not always be visible. Check for pin hole leaks with a piece of cardboard, not your hand.



NEVER perform work or inspection on the machine with the platform elevated without first blocking the boom assembly with the Maintenance Chock.

Perform scheduled maintenance at recommended intervals. Failure to perform scheduled maintenance at recommended intervals may result in a defective or malfunctioning machine and may result in injury or death of the operator. Keep maintenance records current and accurate.

Immediately report any damage, defect, unauthorized modification or malfunction to your supervisor. Any defect must be repaired prior to continued use. DO NOT use a damaged, modified or malfunctioning machine.



Never leave hydraulic components or hoses open. Plug all hoses and fitting immediately after disassembly to protect the system from outside contamination (including rain).

Never open a hydraulic system when there are contaminants in the air.

Always clean the surrounding area before opening hydraulic systems.

Use only recommended lubricants. Improper lubricants or incompatible lubricants may cause as much damage as no lubrication.

Watch for makeshift “fixes” which can jeopardize safety as well as lead to more costly repair.

Inspection and maintenance should be performed by qualified personnel familiar with the equipment.

Using The Maintenance Chock

WARNING

NEVER perform work or inspection on the machine with the platform elevated without first blocking the boom assembly with the Maintenance Chock.
The Maintenance Chock is heavy. Hold it securely during the installation and removal process.
The Maintenance Chock may rotate around the cylinder rod during machine movement and may fall if it is not held securely in place during installation and removal.

The Maintenance Chock fits over the lift cylinder rod, between the rod end and the end of the cylinder barrel.

Installation

- Remove the Maintenance Chock from the tool storage compartment of the Engine Module (See *Workplace Inspection* on page 14).
- Using the Boom Lift/Lower function, raise the platform to approximately 13 feet (4 m).
- Place the Maintenance Chock over the cylinder rod above the cylinder barrel.
- Using the Boom Lift/Lower function, slowly lower the boom until the Maintenance Chock is secure between the cylinder rod end and the cylinder barrel.

Removal

- Using the Boom Lift/Lower function, raise the platform to approximately 13 feet (4 m) until the Maintenance Chock moves freely.
- Remove the Maintenance Chock from the cylinder rod.
- Store the Maintenance Chock in the tool storage compartment of the Engine Module.

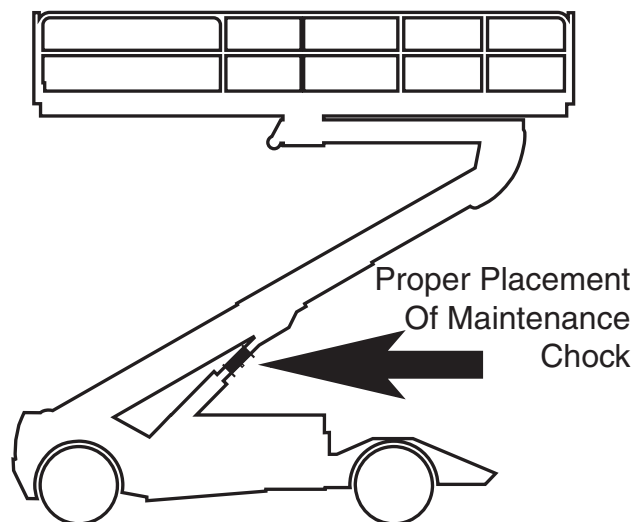
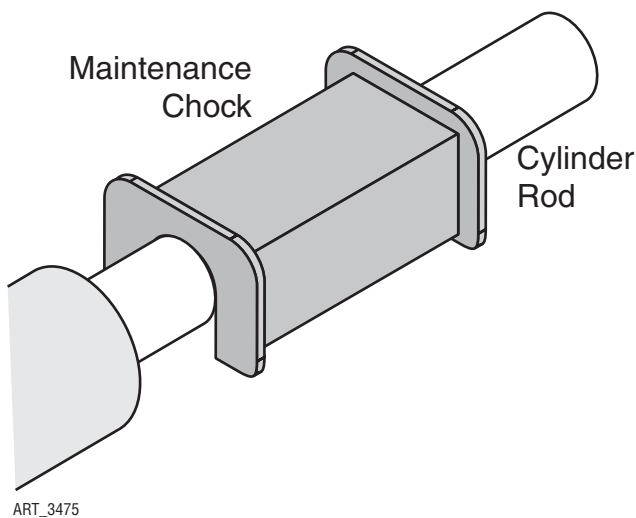

Pre-Start Inspection Checklist

The operator must conduct a Pre-Start Inspection of the machine before each work shift.

DO NOT use a damaged or malfunctioning machine.

Initial	Description
_____	Check that the operator's manual and manual of responsibilities are in the storage container located on the platform.
_____	Perform a visual inspection of all machine components. Look for missing parts; torn or loose hoses; hydraulic fluid leaks; loose, torn or disconnected wires; damaged tires; etc.
_____	Check all structural components of the machine for cracked welds, corrosion and collision damage.
_____	Check the security and condition of the lanyard attachment cables and end connections. Wire ropes should not have any damage, such as cut or frayed strands.
_____	Check all hoses and the cables for worn or chafed areas.
_____	Check the platform rails, the Personnel Entry Gate and the Material Loading Gates for damage or modification. Check for missing spring pin retainers.
_____	Check that all warning and instructional decals are legible and secure.
_____	Check the tires for damage.
_____	All structural components, pins and fasteners are present and properly tightened.
_____	Check for fluid leaks.
_____	Check hydraulic fluid level (check with platform fully lowered and stabilizers fully retracted).
_____	Check engine oil level.
_____	Check engine coolant level at overflow bottle.
_____	Check fuel tank level.
_____	Secure all covers, panels and guard rails.
_____	Ensure that all gates are properly closed and secured before operating the machine.

Frequent Inspection Checklist



This checklist must be used at 3-month intervals or every 150 hours of machine use, whichever occurs first. Failure to do so could result in death or serious injury.

The frequency and extent of periodical examinations may depend on national regulations.

Frequent Maintenance Inspections should be conducted by qualified service technicians only. Photocopy this page for reuse. Keep inspections records up to date. Record and report all discrepancies to your supervisor.

Model Number _____ **Serial Number** _____ **Hour Meter Reading** _____

Initial	Description
---------	-------------

- _____ Perform all checks listed on Pre-Start Inspection.
- _____ Replace engine oil and filter after the first 100 hours of service.
- _____ See Kubota engine operator’s manual for other engine maintenance information.

- _____ Inspect the condition of hydraulic fluid in the reservoir. Oil should be a clear amber color.
- _____ Check battery electrolyte level and connections.
- _____ Check wheel lug nuts for proper torque (see “Machine Specifications”).
- _____ Check if tires are leaning in or out.
- _____ Inspect all structure and pivot points for signs of wear and/or damage.
- _____ Check the pin joints and retaining rings for security.
- _____ Inspect the entire machine for signs of damage, broken welds, loose bolts, improper or makeshift repairs.
- _____ Check that the platform does not drift down with a full load.
- _____ Check all wire connections for tightness and corrosion.
- _____ Check stabilizers for proper operation.
- _____ Check the operation speeds to ensure they are within specified limits (see *Specifications*).
- _____ Check the emergency lowering system.
- _____ Clean and lubricate all push button switches with dry lubricant and ensure that the switches operate freely in all positions.
- _____ Check the tightness of the platform frame and the linkage pins.
- _____ Check the overall platform and guardrail component security.
- _____ Check the electrical mounting and hardware connections for security.
- _____ Check the steering kingpins for excessive play.

Additional maintenance requirements for severe conditions

- _____ If the machine is used in very dusty, exceptionally hot or exceptionally cold conditions, replace hydraulic filter element (under normal conditions replace every 6 months or 300 hours, whichever comes first).

DATE _____ **INSPECTED BY** _____

Annual Inspection Report



Annual Inspection Report

MEC Aerial Platform Sales Corp.
 1401 S. Madera Avenue • Kerman, CA 93630 USA
 800-387-4575 • 559-842-1500 • Fax: 559-842-1522

Date _____
 Serial Number _____
 Model Number _____
 Date Of Last Inspection _____
 Date Placed In Service _____

Customer _____
 Street _____
 City/State/Zip _____
 Phone Number _____
 Contact _____

Dealer _____
 Street _____
 City/State/Zip _____
 Phone Number _____
 Contact _____

- Check each item listed below.
- Use proper Operator's, Service and Parts manual for specific information and settings.
- If an item is found to be "Unacceptable" make the necessary repairs and check the "Repaired" box.
- When all items are "Acceptable", the unit is ready for service.

Key: "Y" Yes/Acceptable
 "N" No/Unacceptable
 "R" Repaired
 "U" Unnecessary/Not Applicable

	Y	N	R	U		Y	N	R	U		Y	N	R	U
Decals:					Base:					Operation:				
Proper Placement/Quantity					Cover Panels Secure					Wires Tight				
Legibility					Base Fasteners Tight					Switches Secure				
Correct Capacity Noted					Bolts Tight					All Functions Operational				
Rails:					Front Axle Mounting (4WD)					Emergency Down:				
All Rail Fasteners Secure					Rear Axle Mounting (4WD)					Operational				
Entry Gate Closes Properly					Front Axle/Front Wheel Assemblies:					Slow Speed Limit Switch:				
Manual/Safety Data In Box					Wheel Motors-Mounting Secure					Set Properly				
Platform:					Wheel Motors-Leaks					Limit Switches Adjusted				
Platform Bolts Tight					Lug Nuts Torqued Properly					Pressures & Hydraulics:				
Platform Structure					Steering Cylinder Pins Secure					Oil Filter Secure/Chg				
Wire Rope for Lanyards Tight and Undamaged					Pivot Points Lubed					Oil Level Correct/Chg				
All Decals Present And Legible					Wheel Assemblies:					Steering Pressure Set				
Load Zone Instructions Present					Brakes Operational					Drive Pressure Set				
Wire Harnesses:					Wheel Motors-Mounting Secure					Lift Pressure Set				
Mounted Correctly					Wheel Motors-Leaks					Engine:				
Physical Appearance					Lug Nuts Torqued Properly					Engine Mounts Tight				
110/220V Outlet Safe/Working					Axle Lock Operational					Fuel Lines Secure				
Elevating Assembly:										Fuel Lines Free Of Leaks				
Boom Structures					Component Area:					Fuel Tanks Secure				
Welds					Valve Manifold(s) Secure					Fuel Shut Off Valves Func.				
Retaining Rings					Hoses Tight/No Leaks					All Shields/Guards In Place				
Cylinder Pins Secure					D/C Mtr(s) Secure/Operational					Oil Level				
Boom/Carriage Shimming					Contactors Secure					Oil Filter				
Torque on Slew Ring Bolts					Pump Secure					Air Filter				
Transport Locks:					Batteries:					Maintenance Chock Present				
Secure					Secure					Operator's Manual Present:				
Operational					Fully Charged					Manual Of Responsibilities Present:				
Stabilizers Operating Correctly					Emergency Stop:									
					Breaks All Circuits									

Comments: _____

Signature/Mechanic: _____ Date: _____
 Signature/Owner-User: _____ Date: _____

P/N 90728 TITAN Boom™



Maintenance

DO NOT operate this machine until you have read and understood this manual, have performed the Workplace Inspection, Pre-Start Inspection and Routine Maintenance, and have completed all the test operations detailed in the Operating Instructions section.

Tag and remove a damaged, malfunctioning or modified machine from service. DO NOT use a damaged, malfunctioning or modified machine.

Use the Pre-Start Inspection to determine what Routine Maintenance is required. The operator may perform only the routine maintenance items specified in this manual.

IMPORTANT—Scheduled maintenance inspection checklists are included in this manual for use only by qualified service technicians. Only qualified service technicians may perform repairs to the machine. After repairs are completed, the operator must perform a Pre-Start Inspection before proceeding to the Functions Test.



Hydraulic fluid under pressure can penetrate and burn skin, damage eyes, and may cause serious injury, blindness, and death. Repair leaks immediately. Fluid leaks under pressure may not always be visible. Check for pin hole leaks with a piece of cardboard, not your hand.



NEVER perform work or inspection on the machine with the platform elevated without first blocking the boom assembly with the Maintenance Chock.

Failure to perform scheduled maintenance at recommended intervals may result in injury or death. Keep maintenance records current and accurate.

Immediately report any damage, defect, unauthorized modification or malfunction to your supervisor. Any defect must be repaired prior to continued use. DO NOT use a damaged, modified or malfunctioning machine.



Never leave hydraulic components or hoses open. Plug all hoses and fitting immediately after disassembly to protect the system from outside contamination (including rain).

Never open a hydraulic system when there are contaminants in the air.

Always clean the surrounding area before opening hydraulic systems.

Use only recommended lubricants. Improper lubricants or incompatible lubricants may cause as much damage as no lubrication.

Watch for makeshift "fixes" which can jeopardize safety as well as lead to more costly repair.

Inspection and maintenance should be performed by qualified personnel familiar with the equipment.

Routine Maintenance

IMPORTANT— The operator may perform only maintenance items on the Pre-Start Inspection Checklist. Frequent and Annual maintenance must be performed by qualified service technicians.

Pre-Start Inspection Perform routine maintenance as identified in the *Pre-Start Inspection Checklist* on page 37.

Frequent and Annual Maintenance

Frequent Inspection Checklists and Annual Inspection Reports must be completed by qualified service technicians trained and authorized to perform maintenance on this machine, and must be done in accordance with the procedures outlined in the service manual. Scheduled maintenance inspection checklists are included in this manual for use by qualified service technicians.

Machines that have been out of service for more than three months must have the Frequent Inspection Checklists completed before returning to service.

Lubrication

Operator may perform routine maintenance only. Lubrication listed as Scheduled Maintenance must be performed by a qualified service technician.

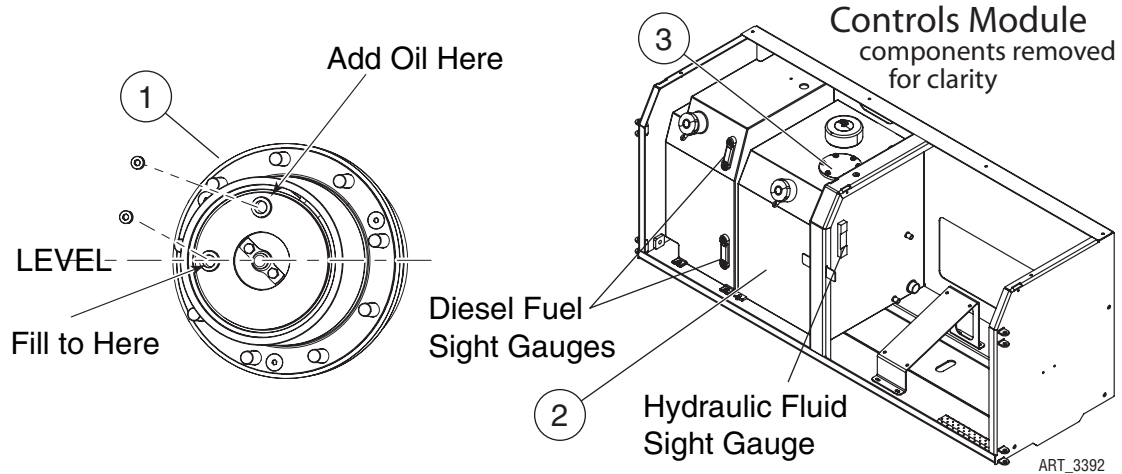

Lubrication

No.	ITEM	SPECIFICATION	FREQUENCY
1	Hubs	SAE 90 Multipurpose Hypoid Gear Oil API Service Classification GL5	Scheduled Maintenance Check every three months or 150 hours, whichever occurs first Change yearly or every 600 hours, whichever occurs first
2	Hydraulic Reservoir	Fluid Type Mobile 424 Mobile DTE13M Mobile DTE11M Do not substitute other fluids as pump damage may result. Fill to the middle of the sight gauge with platform in the stowed position and stabilizers retracted.	Temperature Range > 30° F (0° C) 0° F (-18° C) ~ 30° F (0° C) < 0° F (-18° C) Routine Maintenance Check level daily Scheduled Maintenance Change yearly or every 600 hours, whichever occurs first
3	Hydraulic Filter	Filter Element (located inside Hydraulic Reservoir)	Scheduled Maintenance Normal Conditions Change every six months or 300 hours, whichever occurs first Severe Conditions--very dusty, exceptionally hot or exceptionally cold conditions Change every three months or 150 hours, whichever occurs first

Warning and Instructional Decals

All warning and instructional decals must be present, legible and secure.

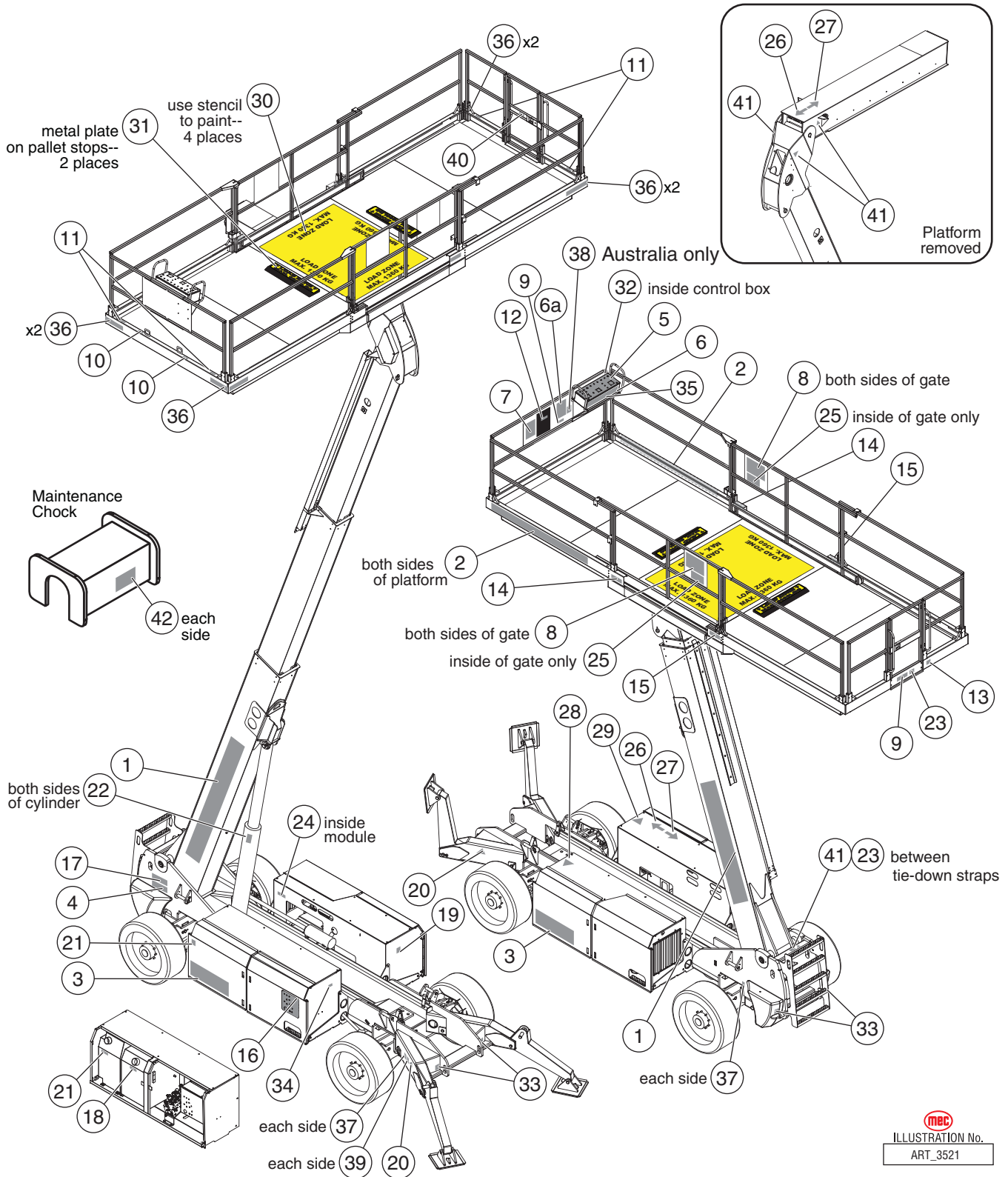

MEC
ILLUSTRATION No.
ART_3521

Decals (continued)















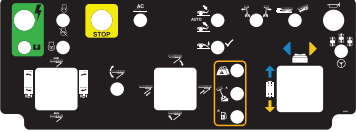

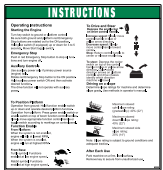

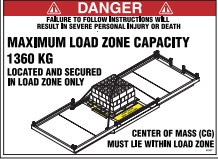
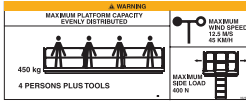





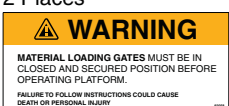
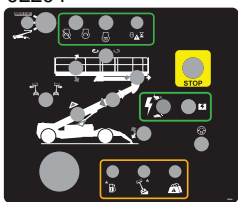

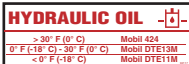



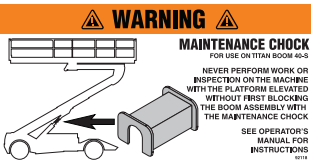
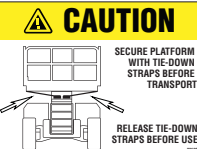







- 1 92050 2 Places

- 2 92049 2 Places

- 3 92051 2 Places

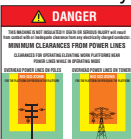
- 4 92054

- 5 92295

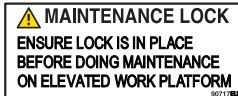
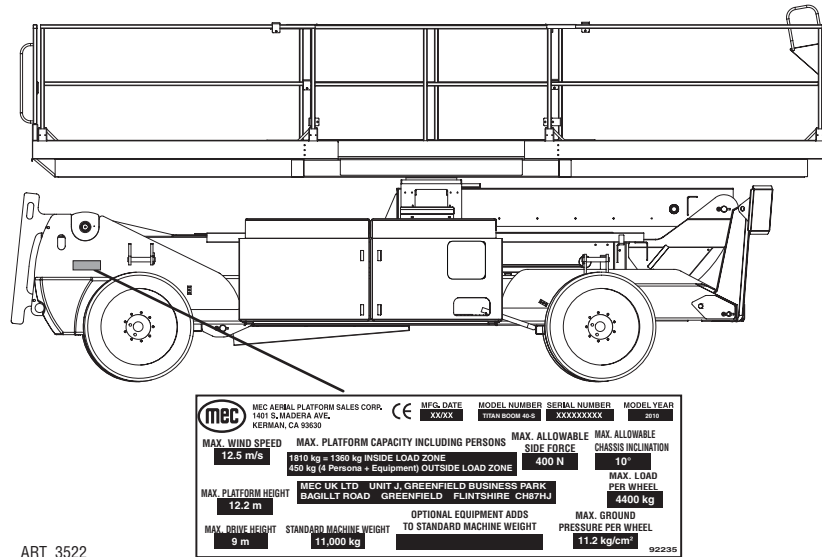
- 6 92056

- 6a 92233

- 7 92411

- 8 92297 4 Places

- 9 92298 2 Places

- 10 92542 2 Places

- 11 92116 4 Places

- 12 8911

- 13 90739

- 14 92410 2 Places

- 15 92058 2 Places

- 16 92294

- 17 92235

- 18 92117

- 19 9052

- 20 91850 2 Places

- 21 91975 2 Places

- 22 92118 2 Places

- 23 92120 2 Places

- 24 92119

- 25 92114 2 Places

- 26 91971 2 places

- 27 91972 2 places

- 28 91981

- 29 91982

- 30 22623 -- Paint Stencil for Load Zone 4 places - not a decal

- 31 22558 -- Metal Plates on Pallet Stops 2 places

- 32 92236

- 33 11026730 4 Places

- 34 90751

- 35 91388

- 36 7982 8 Places -- 2 each corner

- 37 92299 4 Places

- 38 91325 Australia only

- 39 92548 2 Places

- 40 92549

- 41 9910 4 Places

- 42 90717EUR 2 Places

ILLUSTRATION No. ART_3520

Serial Plate Location

The serial plate is attached to the machine at the time of manufacture. Important information about the machine is recorded on the serial plate.



Serial Plate Description

MFG DATE. Month / Year of manufacture

MODEL NUMBER. Identifies the machine.

SERIAL NUMBER. Identifies a machine with reference to its original owner. Refer to the number when requesting information or ordering parts.

MAX. PLATFORM CAPACITY INCLUDING PERSONS. The maximum safe load (material, persons + equipment) which can be correctly placed on the platform at any elevation.

MAX. PLATFORM CAPACITY OUTSIDE LOAD ZONE. The maximum safe load (persons + equipment) which can be evenly distributed outside the load zone of the platform at any elevation.

MAX. SIDE LOAD. The maximum safe force that the occupant can exert laterally on an object outside the platform.

MAX. PLATFORM HEIGHT. The maximum attainable height measured from level ground surface to platform floor.

MAX. DRIVE HEIGHT. The maximum safe platform height at which the machine can be driven.

MAX. WHEEL LOAD. The maximum safe weight applied to each wheel. Calculated with all available options installed.

$$F_w = 30\% (W_m + W_c + W_{opt})$$

MAX. GROUND PRESSURE. The amount of pressure exerted on the surface at each wheel. Calculated with all available options installed.

$$P_{max} = 30\% (W_m + W_c + W_{opt}) / \text{Contact Area}$$

STANDARD MACHINE WEIGHT. The weight of the machine with no options.

OPTIONAL EQUIPMENT ADDS TO STANDARD MACHINE WEIGHT. The weight of installed optional equipment.

Troubleshooting



Should you experience erratic operation or notice any malfunction while operating this machine, discontinue use immediately. Call for assistance and report the incident to your supervisor, and do not use the machine until it has been checked by a trained, qualified mechanic.

Machine functions will not operate

- Master disconnect turned on?
- Battery properly connected?
- Battery fully charged?
- Circuit Breaker tripped?
- Function toggle switch or the Enable Switch not activated?
- Selector Key Switch in proper position?
- Both Emergency Stop Switches reset?
- Hydraulic fluid level low?
- Obvious fluid leak or damaged component?
- Wires disconnected, broken, or loose?

Motor control processor Diagnostic LED OFF?

LED should be ON. If not ON or if FLASHING, refer to Service Manual or contact MEC Technical Support.

Transport and Lifting Instructions

Safety Information



This section is provided for reference and does not supersede any government or company policy regarding the loading, transport or lifting of MEC machinery.

Truck drivers are responsible for loading and securing machines, and should be properly trained and authorized to operate MEC machinery. Drivers are also responsible for selecting the correct and appropriate trailer according to government regulations and company policy. Drivers must ensure that the vehicle and chains are strong enough to hold the weight of the machine (see the serial number plate for machine weight).

Loading

Free-wheel configuration for Winching or Towing.



RUNAWAY HAZARD!

After releasing the brakes there is nothing to stop machine travel. Machine will roll freely on slopes. ALWAYS chock the wheels before manually releasing the brakes.

The machine can be winched or towed short distances at speeds not to exceed 5 MPH (8 km/h). Before towing or winching the machine, it is necessary to release the brakes. Reset the brakes after towing or winching.

Disengage Brakes before Towing or Winching

- Chock the wheels.
- Remove the Torque Engage Cap and reinstall with the bump facing inward on all four (4) hubs.

Engage Brakes before Driving

- Remove the Torque Engage Cap and reinstall with the bump facing outward on all four (4) hubs.

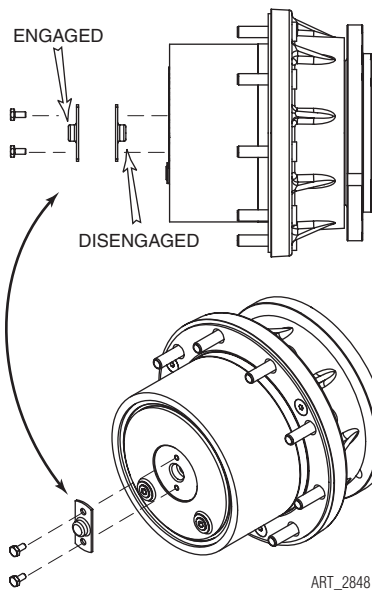

Driving or Winching onto or off of a Transport Vehicle



Always attach the machine to a winch when loading or unloading from a truck or trailer by driving. Read and understand all safety, control, and operating information found on the machine and in this manual before operating the machine.

- Attach the machine to a winch.
- Remove all machine tie downs. Remove wheel chocks.

Driving

- Turn the Base Key Switch to PLATFORM. Check that the Emergency Stop Switch is reset by turning it clockwise.
- Enter the platform and reset the Platform Emergency Stop Switch.
- Test platform control functions.
- Carefully drive the machine off the transport vehicle with the winch attached.

Note: The brakes are automatically released for driving and will automatically apply when the machine stops.

Winching

- Disengage brakes (see *Disengage Brakes before Towing or Winching* on page 46).
- Carefully operate the winch to lower the machine down the ramp.
- Chock the wheels and engage the brakes.

Securing to Truck or Trailer for Transport

- Turn the key Selector Key Switch to OFF and remove the key before transport.
- Turn the Battery Disconnect Switch to OFF before transport.
- Inspect the entire machine for loose or unsecured items.
- Use the ratcheting tie-down straps mounted in front of the entry ladder to secure the rear of the deck to the chassis. Attach each strap to the tie-down points on the bottom of the platform corners (see illustration).

Note: Release the ratcheting tie-down straps from platform before use

- Use a minimum of two (2) chains or straps of adequate load capacity.
- Adjust the rigging to prevent damage to chains or the machine.

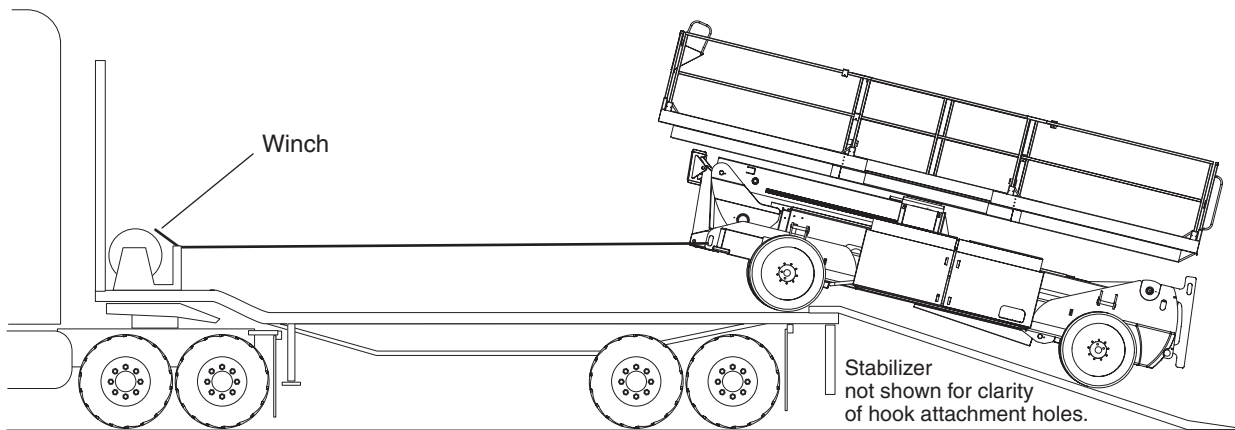

Platform Tie Down Straps

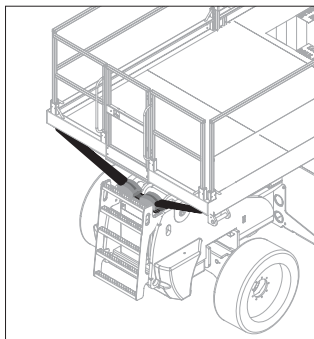

Truck Tie Down

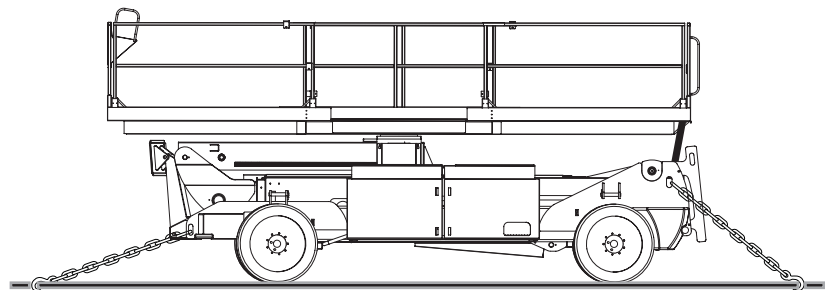

ART_4185

Lifting Instructions



WARNING

Only qualified riggers should rig and lift the machine.

Ensure that the crane capacity, loading surfaces and straps are sufficient to withstand the machine weight. See the serial plate for the machine weight.

- 1 Begin with the platform fully lowered and retracted. Be sure that the module doors are closed and secure. Remove all loose items from the machine.
- 2 Secure the Material Loading Gates and the Personnel Entry Gate in open positions.

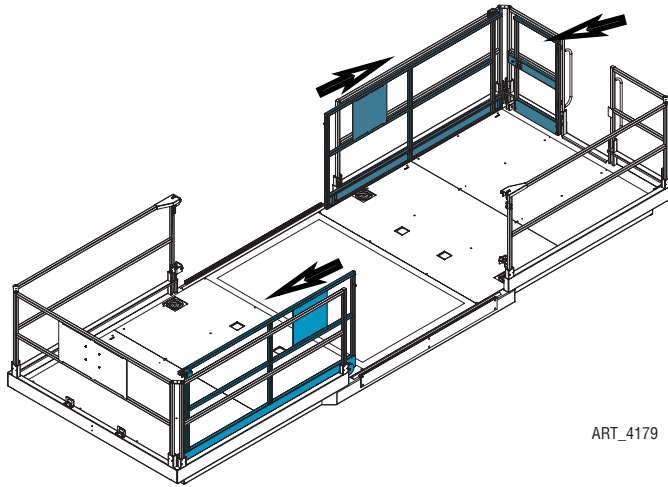

ART_4179

- 3 Use the Platform Slide function to slide the platform forward approximately 18 inches (46 cm). Use the ratcheting tie-down straps to secure the corners of the platform.

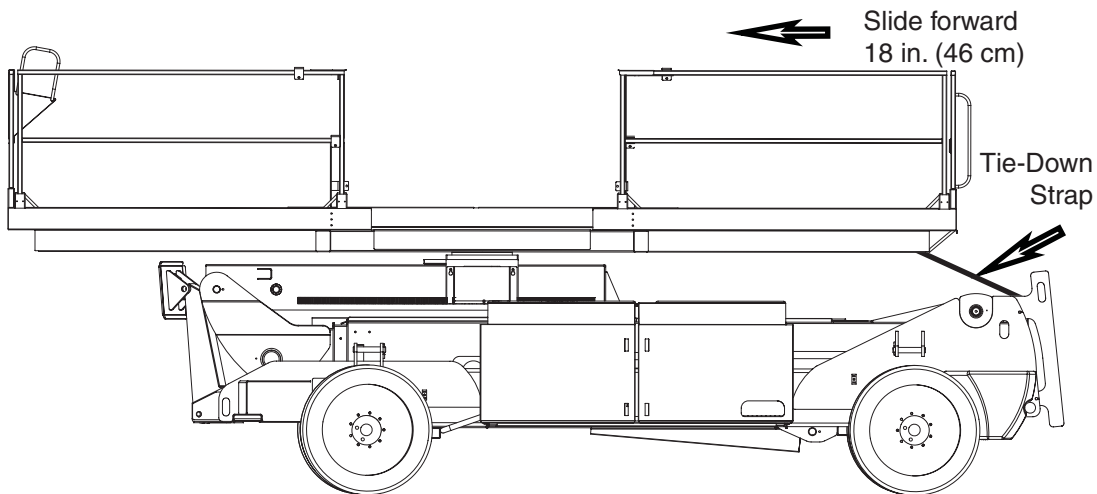

ART_4180

4 Locate the lift points.

- Front lift points are located in the front axle.
- Rear lift points are at the rear of the machine chassis.

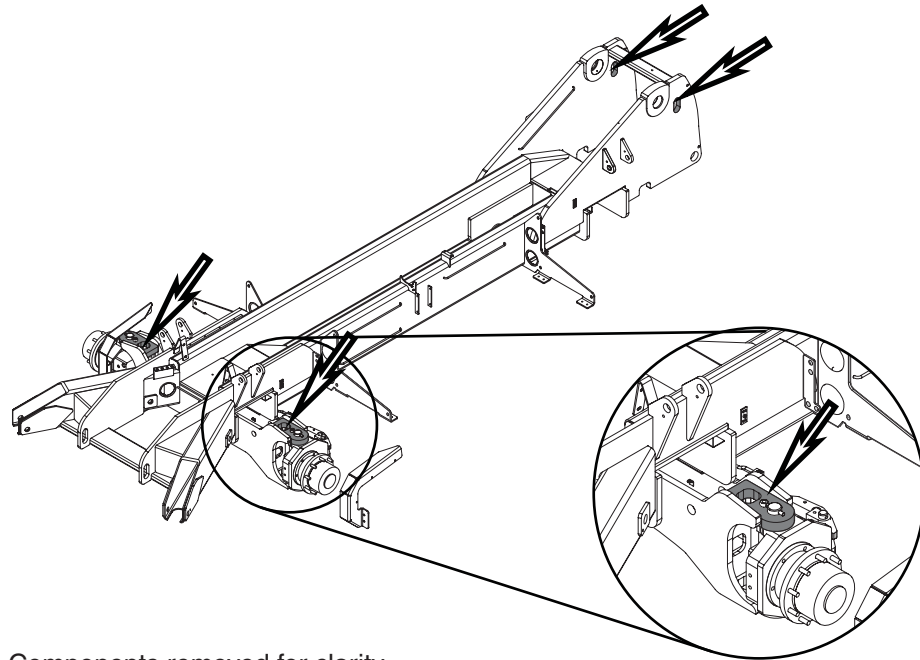

Components removed for clarity

ART_4181

5 Locate the machine's center of gravity.

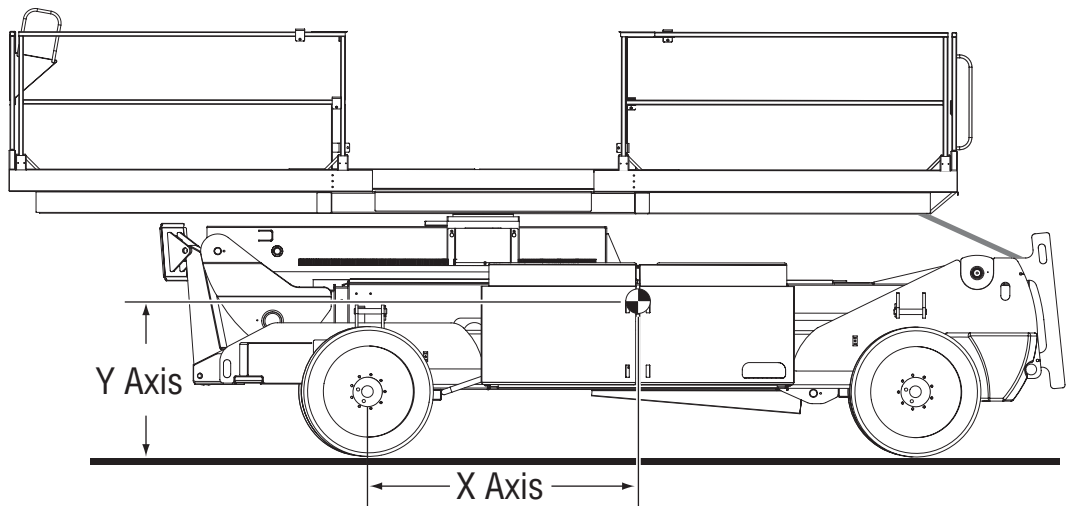

Center of Gravity	X Axis	Y Axis
Titan Boom™ 40-S	79 in. / 200 cm	37 in. / 94 cm

ART_4184

- 6 Attach lifting straps, chains or cables of adequate capacity to the lifting points previously designated. Route through the open gates as shown.

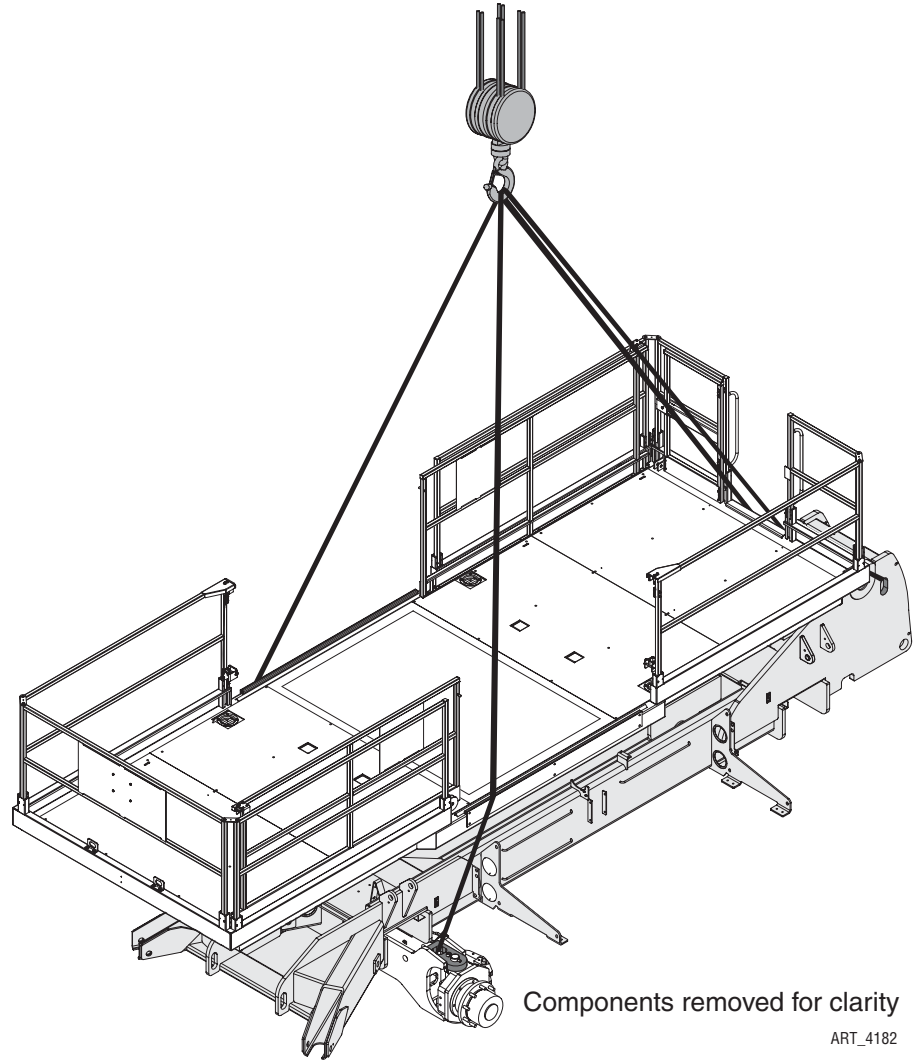

ART_4182

- 7 Carefully lift the machine.

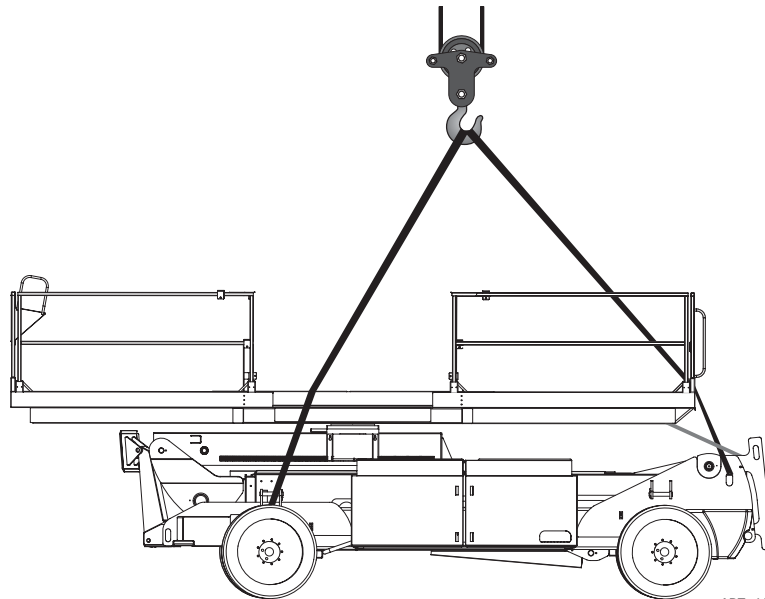

ART_4183

NOTES:

Powered Access Certification Ltd, PO Box 98, Windermere, Cumbria, LA23 1WF, UK
 EC Notified Body Number 0545



EC Type Examination Certificate

Certificate Number	CE10/13549/PAC
Test Report Summary Number	CE10/13549/TRS452
Technical File Number	TF/MEC/2348
Manufacturer	MEC Aerial Work Platforms
Address	1401 S.Madera Avenue Kerman CA 93630 USA
Authorised representative (if applicable)	MEC Europe Unit J, Greenfield Business Park Bagillt Road, Greenfield, Flintshire, CH8 7HJ, UK.
Product type	Mobile Elevating Work Platform
Model	Titan Boom 40-S
Serial number	12400026

This is to certify that the above product has been assessed, tested and approved by Powered Access Certification Limited in accordance with the requirements of the European Council Directive 2006/42/EC on Machinery, as detailed in the above Test Report Summary. Guidance has been taken from the relevant European harmonised standards stated below. This certificate is subject to the company manufacturing in conformity with the approved technical file and informing PAC Limited of any modifications, even of a minor nature, made or planned to be made, to the above product.

Relevant harmonised standards	BS EN 280:2001 + A2:2009 Mobile elevating work platforms Design Calculations - Stability criteria – Construction - Safety - Examinations and tests
-------------------------------	--

Date of Issue	30th November 2010
Date of Expiry	30th November 2015

Signed  (Managing Director)





Limited Owner Warranty

MEC Aerial Platform Sales Corp. warrants its equipment to the original purchaser against defects in material and/or workmanship under normal use and service for one (1) year from date of registered sale or date the unit left the factory if not registered. MEC Aerial Platform Sales Corp. further warrants the structural weldments of the main frame and scissor arms to be free from defects in material or workmanship for five (5) years from date of registered sale or date unit left the factory if not registered. Excluded from such warranty is the battery(s) which carries a ninety (90) day warranty from described purchase date. Warranty claims within such warranty period shall be limited to repair or replacement, MEC Aerial Platform Sales Corp's option, of the defective part in question and labor to perform the necessary repair or replacement based on MEC Aerial Platform Sales Corp's then current flat rate, provided the defective part in question is shipped prepaid to MEC Aerial Platform Sales Corp. and is found upon inspection by MEC Aerial Platform Sales Corp. to be defective in material and/or workmanship. MEC Aerial Platform Sales Corp. shall not be liable for any consequential, incidental or contingent damages whatsoever. Use of other than factory authorized parts; misuse, improper maintenance, or modification of the equipment voids this warranty. The foregoing warranty is exclusive and in lieu of all other warranties, express or implied. All such other warranties, including implied warranties of merchantability and of fitness for a particular purpose, are hereby excluded. No Dealer, Sales Representative, or other person purporting to act on behalf of MEC Aerial Platform Sales Corp. is authorized to alter the terms of this warranty, or in any manner assume on behalf of MEC Aerial Platform Sales Corp. any liability or obligation which exceeds MEC Aerial Platform Sales Corp's obligations under this warranty.



MEC Aerial Platform Sales Corp.

1401 South Madera Ave • Kerman, CA 93630 USA
Ph: 1-877-635-5438 • 559-842-1500 • Fax: 559-842-1522
www.mecawp.com